



680KG AIR/HYDRAULIC MOTORCYCLE LIFT 680KG AIR/HYDRAULIC MINI TRACTOR/QUAD/ MOTORCYCLE LIFT

MODEL NO'S: **MC680A, MT680.V4**

Thank you for purchasing a Sealey product. Manufactured to a high standard, this product will, if used according to these instructions, and properly maintained, give you years of trouble free performance.

IMPORTANT: PLEASE READ THESE INSTRUCTIONS CAREFULLY. NOTE THE SAFE OPERATIONAL REQUIREMENTS, WARNINGS & CAUTIONS. USE THE PRODUCT CORRECTLY AND WITH CARE FOR THE PURPOSE FOR WHICH IT IS INTENDED. FAILURE TO DO SO MAY CAUSE DAMAGE AND/OR PERSONAL INJURY AND WILL INVALIDATE THE WARRANTY. KEEP THESE INSTRUCTIONS SAFE FOR FUTURE USE.



Refer to instruction manual



Wear protective gloves



Wear safety footwear



Warning: Crushing of Hands

1. SAFETY

- ✓ Disconnect lift from air supply before changing parts, servicing or performing any maintenance.
- ❑ **WARNING!** Ensure correct air pressure is maintained and not exceeded. Recommended pressure 100-120psi. Required air flow 9.5cfm.
- ✓ Keep air hose away from heat, oil and sharp edges. Check air hose for wear before each use, and ensure that all connections are secure.
- ✓ Ensure lift is kept clean and in good working order. Immediately repair or replace damaged parts.
- ✓ Use recommended parts only. Incorrect parts may be dangerous and will invalidate the warranty.
- ✓ Use a qualified person to lubricate and maintain the lift. **DO NOT** use brake fluid to top up system. Use Sealey hydraulic oil only.
- ✓ Locate lift in a suitable, well lit work area. Keep area clean and tidy and free from unrelated materials.
- ✓ Use lift on level and solid ground, preferably concrete. *Avoid tarmacadam since lift may sink in.*
- ✓ Ensure all non-essential persons keep a safe distance.
- ✓ Always keep your hands and feet away from moving parts. **DO NOT** reach under the lift.
- ✗ **DO NOT** operate the lift if parts are missing or damaged.
- ✗ **DO NOT** adjust the safety overload valve.
- ✓ Keep the lift clean for best and safest performance.
- ✓ The maximum load is 680Kg. **DO NOT** exceed this rated capacity.
- ✓ Use this lift for lifting purpose only. **DO NOT** use it for any other purpose it is not designed to perform.
- ✓ Keep children and unauthorised persons away from the work area.
- ✓ Remove ill fitting clothing. Remove ties, watches, rings and other loose jewellery, and contain long hair.
- ✓ Keep proper balance and footing, **DO NOT** overreach and wear non-slip footwear.
- ✓ Ensure the vehicle is adequately secured to the lifting platform with appropriate straps.
- ✓ When the platform is being raised, ensure the safety handle is moved to the right hand side of its detent, to engage the safety plate, (see section 6.1.5).
- ✓ Before lowering lift ensure that there are no obstructions underneath and that all persons are standing clear.
- ✗ **DO NOT** use the lift if damaged, any suspect parts are noted or it has been subjected to a shock load.
- ✗ **DO NOT** operate the lift when you are tired or under the influence of alcohol, drugs or any intoxicating medication.
- ✗ **DO NOT** allow untrained persons to operate the lift.
- ✗ **DO NOT** make any modifications to the lift.
- ✗ **DO NOT** get the lift wet.
- ✗ **DO NOT** pull the hose from the air supply, and **DO NOT** direct air from the air hose at yourself or others.
- ✓ When not in use disconnect lift from the air supply, and store in the down position in a safe, dry, childproof area.
- ❑ **WARNING: The warnings, cautions and instructions discussed in this instruction manual cannot cover all possible conditions and situations that may occur. It must be understood that common sense and caution are factors which cannot be built into this product, but must be applied by the operator.**

2. INTRODUCTION

All steel construction with both hydraulic pump and air motor assembly. Combined air and foot pump separate from main lift for choice of operation. Air Consumption 7.06cfm. Ramp and platform made with chequer plate surface to ease loading and positioning of motorcycle. Supplied with motorcycle front wheel locking attachment, securing vehicle to provide easy maintenance access. Fitted with multi-position safety lock to prevent accidental lowering. Suitable for use with centre stand motorcycles or with paddock stand.

MT680.V4: Features two additional side platforms for extra width.

3. SPECIFICATION

Model no:.....	MC680A	MT680.V4
Capacity:.....	680kg	680kg
Minimum height:.....	190mm	190mm
Maximum height:.....	790mm	790mm
Width:	710mm	710mm
Width with side platforms:	1220mm
Length:.....	2000mm	2000mm
Air Supply:	Min.100psi/Max.120psi	Min.100psi/Max.120psi

4. ASSEMBLY

REFER TO PARTS DIAGRAM BELOW (fig.1)

- 4.1. Lay the sliding plate (8) onto the platform (1).
- 4.2. Connect the oil hose coupler (29) to the port on the hydraulic pump (20).
- 4.3. Connect air hose into the end of the air/manual pump (20).
- 4.4. Attach the leading plate (9) to the end of the platform (1).
- 4.5. Insert safety handle (36) through detent on rear end of lift and screw into thread on the bracket on the end of the safety wire (37).
- 4.6. Tighten lock nut (35).
- 4.7. **FIT MOTORCYCLE WHEEL CLAMP**
- 4.8. Fit crank handle assembly (40) to platform (1) through pre-drilled holes, use bolt (5) washer (38) and nut (7).
- 4.8.1. Fit moveable vice jaw (2) to crank handle assembly (40), use bolt (6).
- 4.8.2. Fit fixed vice jaw (3) to platform (1), use bolt (5).
- 4.8.3. Fit stop plate (4) to platform (1), use bolt (5).
- 4.9. **FIT SIDE EXTENSIONS**
- 4.9.1. Pass connecting bars (42) through front and rear holes in platform (1). Slide on side extensions (41).
- 4.9.2. Secure at each end of the connecting bars (42) with position pins (44). Fit pin through hole on the end of the connecting bar and secure with lock nut (34).
- 4.9.3. Fit side extension ramp extensions (43).

Model illustrated: MT680.V4

fig.1

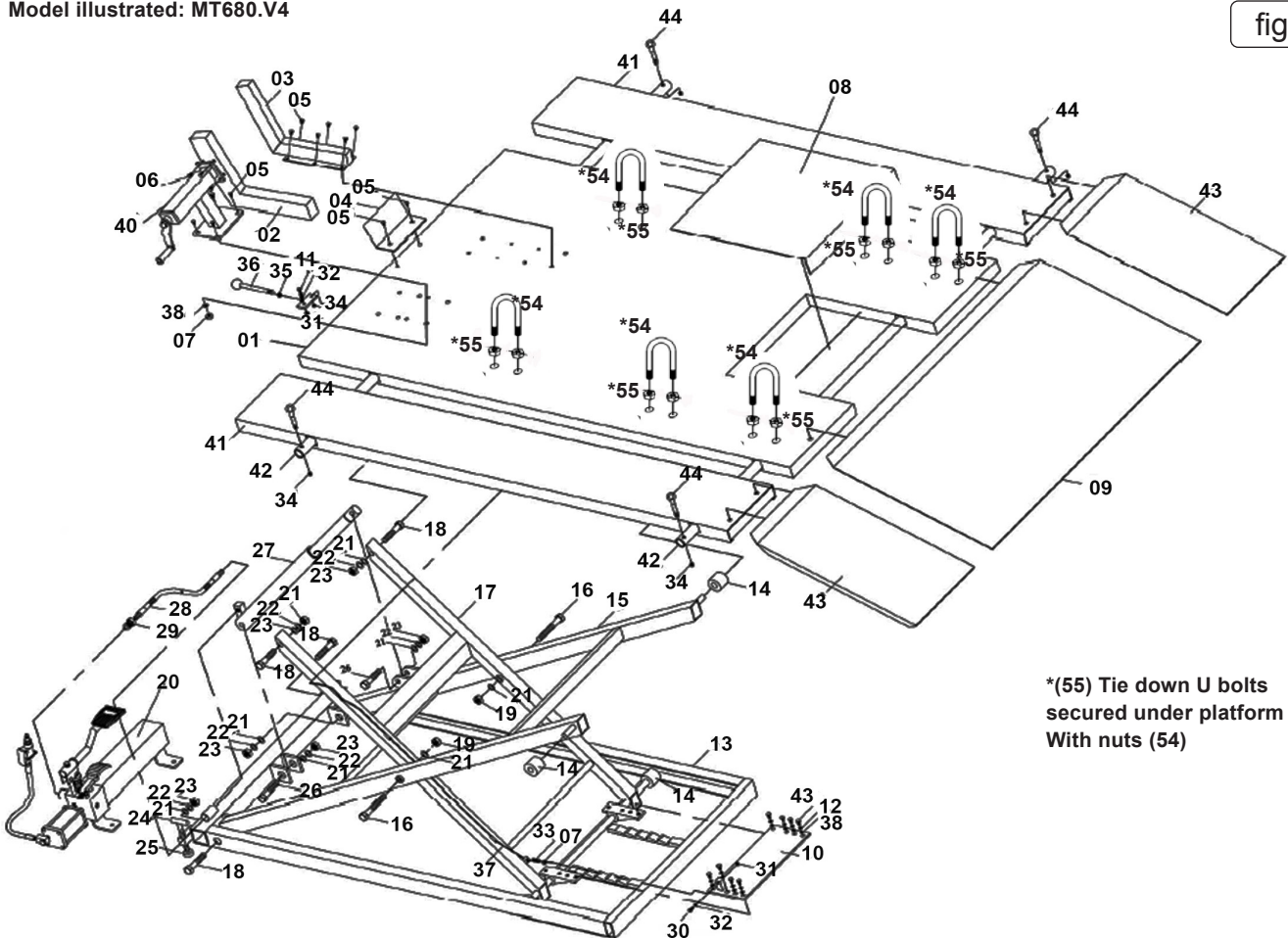

*55) Tie down U bolts secured under platform With nuts (54)

- 4.10. **FIT TIE DOWN U BOLTS (54)** at the 6 locations shown above. Control depth with 2 x nuts (55), pass through platform (1) and secure underneath with 2 x nuts (55).

5. AIR SUPPLY

- 5.1. You will require an air pressure of minimum 100psi, maximum 120psi to get the best performance from this lift.
 - ❑ **WARNING!** Ensure the air supply does not exceed 120psi while operating the lift. Too high an air pressure and unclean air will shorten the product's life due to excessive wear, and may be dangerous, causing possible damage and/or personal injury.
- 5.2. Drain the air tank daily. Water in the air line will damage the lift.
- 5.3. Clean the air inlet filter screen weekly.
- 5.4. Keep the air hose between the compressor and the lift as short as possible, and install an air filter and oiler, (fig 2).
- 5.5. Line pressure should be increased to compensate for unusually long air hoses (over 8 metres). The minimum hose diameter should be 1/4" I.D. and fittings must have the same inside dimensions.

fig.2

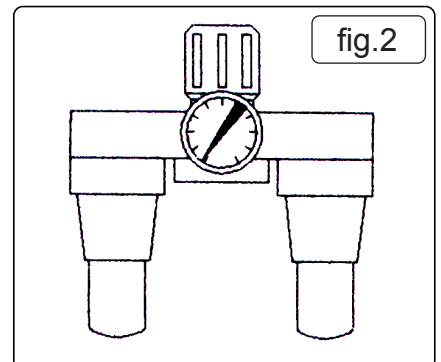

5.6. Keep hose away from heat, oil and sharp edges. Check hoses for wear, and make certain that all connections are secure.

6. PREPARATION FOR USE

6.1. BEFORE USE

- 6.1.1. This lift has a vent valve (figs.3 & 3A). This is closed for transit only. Before use the valve must be lifted or the pump will not function properly.
- 6.1.2. Let the hydraulic pump stand for one hour, to allow the oil to settle, before purging the system.
NOTE: Failure to allow sufficient time for the oil to settle could result in air remaining in the oil. Should the pump fail to purge completely at the first attempt, a second purge will be required.
- 6.1.3. Purge the hydraulic system by depressing the release foot pedal and pumping the lift foot pedal fifteen to twenty times.
- 6.1.4. Test the lift unladen by moving the safety handle to the right and raising the lift to full height (figs.4 & 5).

6.1.5. SAFETY HANDLE OPERATION

- 6.1.5.1. **To raise.** Before raising the lift the safety handle must be moved to the right hand side of the detent (fig.4) to prevent accidental lowering.
- 6.1.5.2. **To lower.** Raise the lift by pumping the foot pedal several times (or by air), to let the safety plate free from its locked position, then move the safety handle to the left and lock it in its detent (fig.5).
- 6.1.5.3. Lower the lift by depressing the release foot pedal slowly, to control the rate of descent.

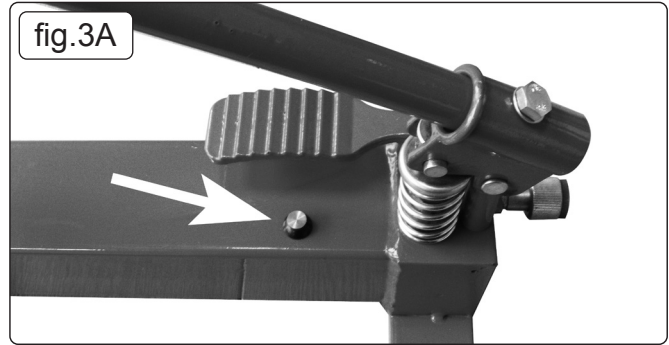
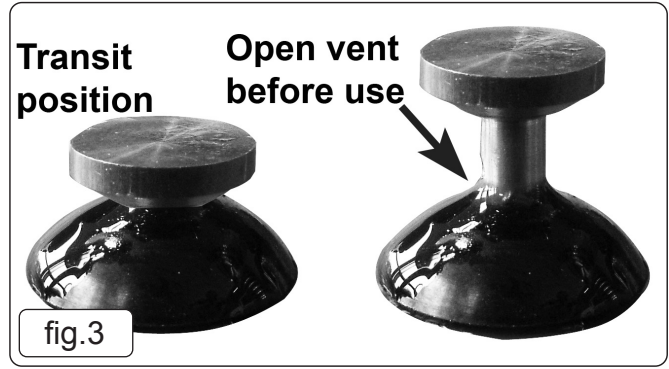

7. OPERATION

- ❑ **WARNING!** Ensure that you read, understand and apply the Section 1 Safety Instructions.
- ❑ **WARNING! DO NOT** overload the vehicle lift. The maximum load is 680kg.
- 7.1. Position the lift in a suitable location, preferably on a concrete surface.
- 7.1.1. Turn the adjustable screws (24) down to ensure that lift is level and stable on the surface.
- ❑ **WARNING!** The vehicle must be fully supported by the lift platform prior to lifting. **DO NOT** put the rear wheel of the vehicle on the leading plate (9) and **DO NOT** use the leading plate to support the weight of the vehicle when lifting. The leading plate (9) is only used to assist the operator in wheeling the vehicle on the platform when the lift is at its lowest position.
- 7.1.2. Secure the vehicle to the lift platform.
- 7.1.3. When working on a motorcycle, wheel the bike in to the wheel clamp at the front of the lift, tighten the clamp to hold the bike in place.
- 7.1.4. Press on the air valve to raise the lift. The air valve can be locked in the on position (figs.6 and 7).
- 7.1.5. Before lowering, ensure that all tools and parts are removed from beneath the table.

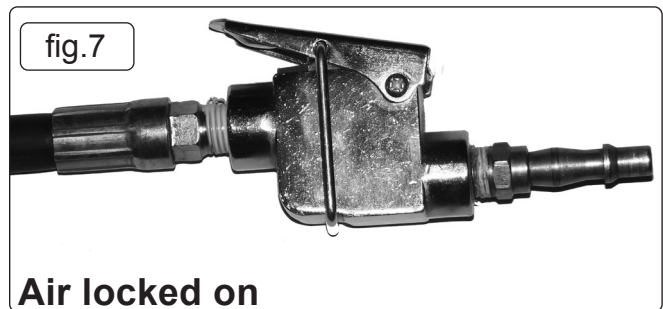

8. MAINTENANCE

- 8.1. Clean and lubricate on a regular basis.
- 8.2. Regularly check oil level via filler hole (fig 3A). With ramp fully down remove filler plug, oil should be approximately 15mm below the filler hole. Remove filler plug and grommet, top-up as necessary, then replace grommet and filler plug. Use a good quality jack oil such as Sealey Hydraulic Jack Oil. **DO NOT** use brake fluid. **DO NOT** overfill.
- 8.3. *Ensure no dirt enters hydraulic system when filling or removing/replacing components.*
- 8.4. Lubricate the air motor with a good quality jack oil such as Sealey Hydraulic Jack Oil, once or twice a month. Add the oil through the air valve whilst holding down the lever.
- 8.5. Always dispose of waste oil according to local authority guidelines. If in doubt consult your local authority.
- 8.6. Keep the lift clean and wipe off any oil or grease. Lubricate all moving parts.
- 8.7. Before each use check all parts. If any part of the lift is damaged or suspect, remove the lift from service and take necessary action to repair.

9. TROUBLESHOOTING

Lift will not lift load.	1. Release valve not fully closed. 2. Oil level low. 3. Air supply low.	1. Close valve firmly. 2. Top-up to correct level. 3. Min. requirement 100psi.
Lift will not lift load.	1. Release valve not fully closed.	1. Close valve firmly.
Lift will not lift smoothly or to full height.	1. Oil level low. 2. Air in hydraulic system.	1. Top-up to correct level. 2. Bleed system.
Lift will not lower completely.	1. Release valve not sufficiently open.	1. Slowly open valve further.

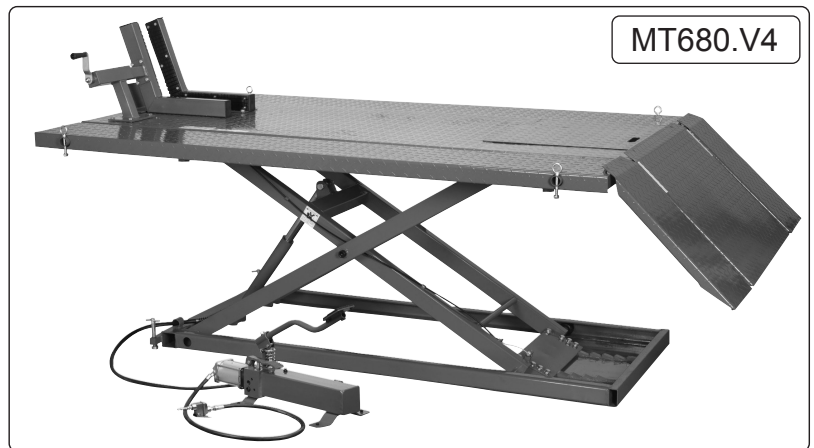

ENVIRONMENT PROTECTION

Recycle unwanted materials instead of disposing of them as waste. All tools, accessories and packaging should be sorted, taken to a recycling centre and disposed of in a manner which is compatible with the environment. When the product becomes completely unserviceable and requires disposal, drain any fluids (if applicable) into approved containers and dispose of the product and fluids according to local regulations.

Note: It is our policy to continually improve products and as such we reserve the right to alter data, specifications and component parts without prior notice. Please note that other versions of this product are available. If you require documentation for alternative versions, please email or call our technical team on technical@sealey.co.uk or 01284 757505. **Important:** No Liability is accepted for incorrect use of this product.

Warranty: Guarantee is 12 months from purchase date, proof of which is required for any claim.

Sealey Group, Kempson Way, Suffolk Business Park, Bury St Edmunds, Suffolk. IP32 7AR



01284 757500



01284 703534



sales@sealey.co.uk



www.sealey.co.uk



EC DECLARATION OF CONFORMITY

Description and Function: **(Mini Tractor/Quad)/Motorcycle Lift 680kg Capacity (Heavy-Duty) Air/Hydraulic**

Model/Type: **MC680A v1 MT680 v4**

Manufacturing Date/Serial Number where applicable:

2006/42/EC Machinery Directive

This declaration of conformity is issued under the sole responsibility of the manufacturer:

Jack Sealey Ltd, Kempson Way, Suffolk Business Park, Bury St Edmunds, Suffolk. IP32 7AR

Declaration of Conformity in accordance with the above Directive(s).

References to harmonised standard(s)

EN 1493:2010.....
.....
.....
.....
.....
.....
.....
.....
.....

Technical file compiled by: **Jack Sealey Ltd**

Being the responsible person appointed by the manufacturer.

Signed *Steve Buckle*.....

Date 30 May 2019.....

Name Steve Buckle.....

Position Marketing Director.....

Place: Bury St Edmunds

Sealey Group, Kempson Way, Suffolk Business Park, Bury St Edmunds, Suffolk. IP32 7AR
📞 01284 757500 📄 01284 703534 ✉ sales@sealey.co.uk 🌐 www.sealey.co.uk

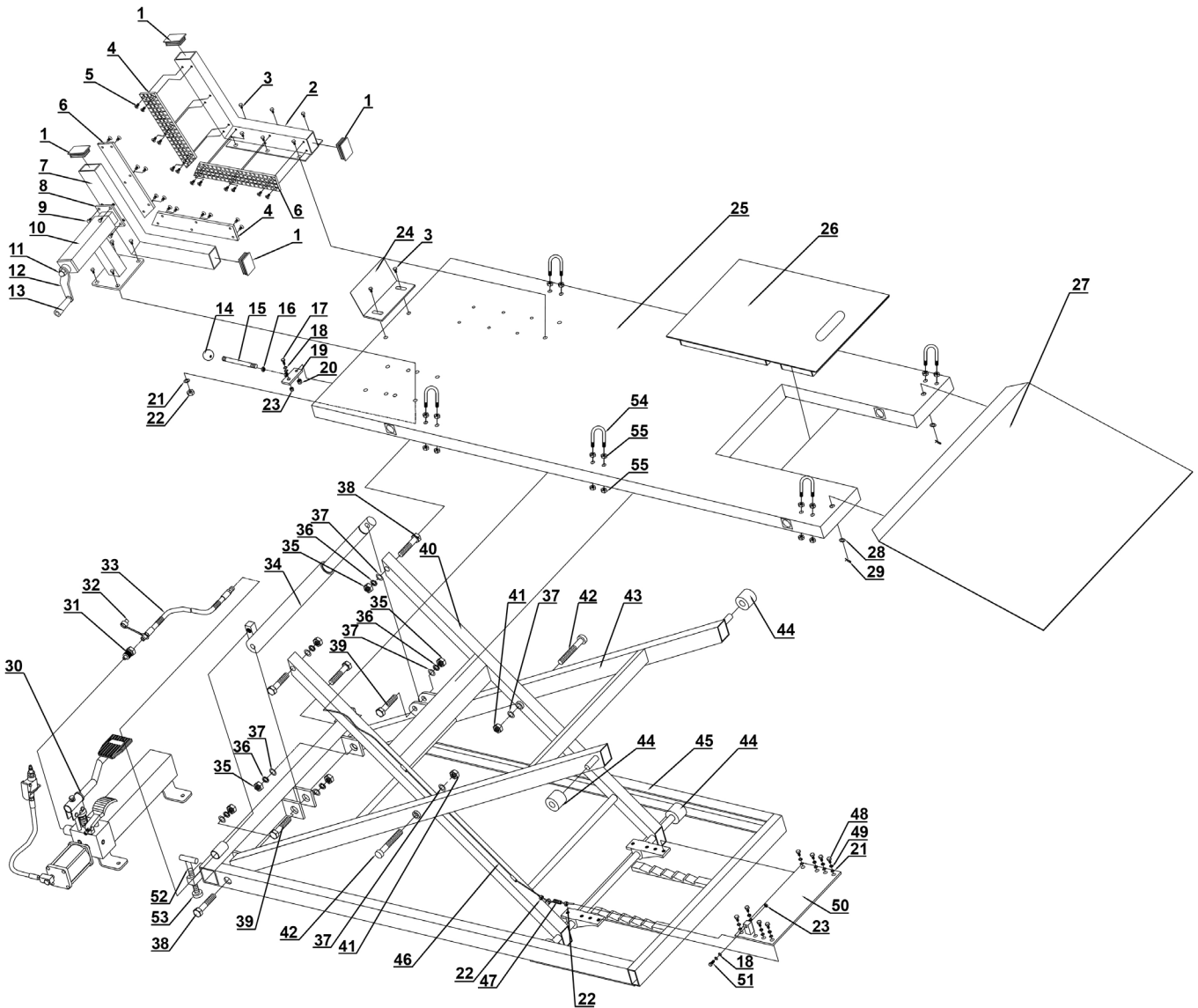

Item	Part No.	Description
1	MC680A.01	Rubber End Cap
2	MC680A.02	Fixed Vice Jaw
3	SS1025.S	Hex Head Set Screw M10 X 25 Zinc
4	MC680A.04	Rubber Pad (A)
5	MSC610.S	Csk Phillips Machine Screw M6 X 10 Zinc
6	MC680A.06	Rubber Pad (B)
7	MC680A.07	Movable Vice Jaw
8	MC680A.08	Crank Handle (Inner)
9	SS816.S	Hex Head Set Screw M8 X 16 Zinc
10	MC680A.10	Crank Handle Assembly
11	SN8.SD	Steel Nut M8 Domed Zinc

Item	Part No.	Description
12	MC680A.12	Rotating Handle
13	MC680A.13	Rotating Handle Grip
14	MC680A.14	Safety Handle Knob
15	MC680A.15	Safety Handle Shaft
16	SN10.S	Steel Nut M10 Zinc
17	SS616.S	Hex Head Set Screw M6 X 16 Zinc
18	FWM6.S	Flat Washer M6 Zinc
19	MC680A.19	Plate
20	NLN10.S	Nyloc Nut M10 Zinc
21	FWM10.S	Flat Washer M10 Zinc
22	SN6.S	Steel Nut M6 Zinc

NOTE: It is our policy to continually improve products and as such we reserve the right to alter data, specifications and component parts without prior notice. There may be alternative versions of this product, please contact us should you require this information.

IMPORTANT: No liability is accepted for incorrect use of product. Spare parts must be fitted by a competent person

WARRANTY: Guarantee is 12 months from purchase date, proof of which will be required for any claim.



Parts Information:
Motorcycle Lift 680kg Capacity Heavy-Duty Air/Hydraulic
Model No: MC680A

Item	Part No.	Description
23	NLN6.S	Nyloc Nut M6 Zinc
24	MC680A.24	Stop Plate
25	MC680A.25	Platform
26	MC680A.26	Removable Plate
27	MC680A.27	Leading Plate
28	FWM6.S	Flat Washer M6 Zinc
29	MC680A.29	R-Pin
30	MC680A.30	Air/Manual Pump
31	MC680A.31	Hose Connector
32	MC680A.32	Dust Cap
33	MC680A.33	Hydraulic Hose 15mm x 1250mm
34	MC680A.34	Ram
35	SN16.S	Steel Nut M16 Zinc
36	SWM16.S	Spring Washer M16 Zinc
37	FWM16.S	Flat Washer M16 Zinc
38	HHB1690.S	Hex Head Bolt M16 x 90mm
39	HHB1690.S	Hex Head Bolt M16 x 90mm
40	MC680A.40	Lifting Arm (Inner)

Item	Part No.	Description
41	NLN16.S	Nyloc Nut M16 Zinc
42	HHB1690.S	Hex Head Bolt M16 x 90mm
43	MC680A.43	Lifting Arm (Outer)
44	MC680A.44	Steel Roller Wheel
45	MC680A.45	Base Assembly
46	MC680A.46	Safety Wire
47	MC680A.47	Double Screw
48	SS1020.S	Hex Head Set Screw M10 X 20 Zinc
49	SWM10.S	Spring Washer M10 Zinc
50	MC680A.50	Safety Support Plate
51	SS630.S	Hex Head Set Screw M6 X 30 Zinc
52	MC680A.52	Adjusting Screw
53	MC680A.53	Rotatable Foot
54	MC680A.54	U-Bolt
55	MC680A.55	Nut for U-Bolt
--	MC680A.RK	Repair kit (not shown)

NOTE: It is our policy to continually improve products and as such we reserve the right to alter data, specifications and component parts without prior notice. There may be alternative versions of this product, please contact us should you require this information.

IMPORTANT: No liability is accepted for incorrect use of product. Spare parts must be fitted by a competent person

WARRANTY: Guarantee is 12 months from purchase date, proof of which will be required for any claim.

Sealey Group, Kempson Way, Suffolk Business Park, Bury St Edmunds, Suffolk. IP32 7AR



01284 757500



01284 703534



sales@sealey.co.uk



www.sealey.co.uk



Parts Information:
Mini Tractor/Quad/Motorcycle Lift 680kg Capacity Air/Hydraulic
Model No: MT680.V4

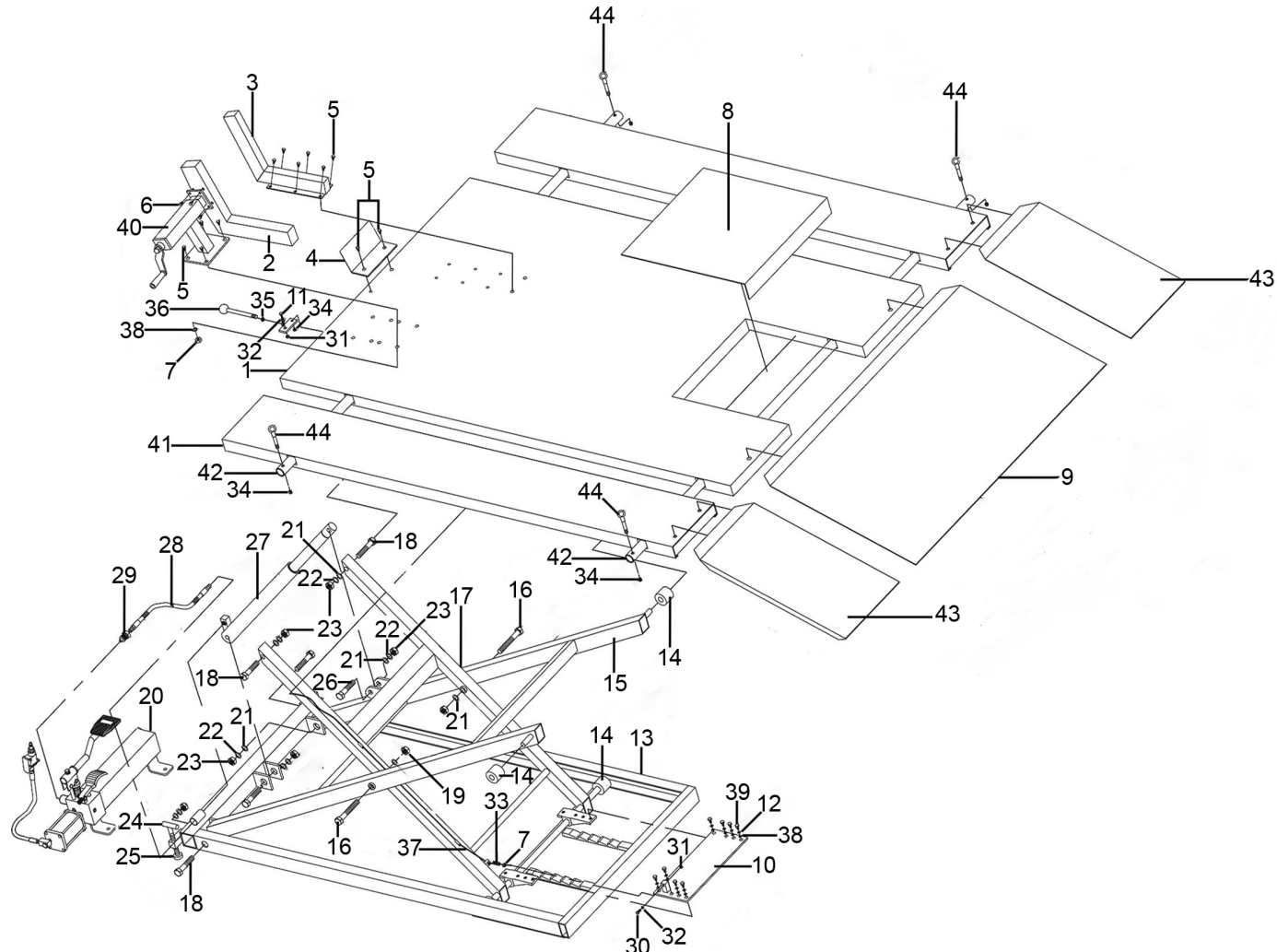

NOTE: It is our policy to continually improve products and as such we reserve the right to alter data, specifications and component parts without prior notice.

There may be alternative versions of this product, please contact us should you require this information.

IMPORTANT: No liability is accepted for incorrect use of product. Spare parts must be fitted by a competent person

WARRANTY: Guarantee is 12 months from purchase date, proof of which will be required for any claim.

Sealey Group, Kempson Way, Suffolk Business Park, Bury St Edmunds, Suffolk. IP32 7AR



01284 757500



01284 703534



sales@sealey.co.uk



www.sealey.co.uk



Parts Information:
**Mini Tractor/Quad/Motorcycle Lift 680kg
Capacity Air/Hydraulic
Model No: MT680.V4**

Item	Part No.	Description
1	MT680.V4-01	Platform
2	MT680.V4-02	Vice Jaw, Moveable
3	MT680.V4-03	Vice Jaw, Fixed
4	MT680.V4-04	Stop Plate
5	MT680.V4-05	Bolt
6	MT680.V4-06	Bolt
7	MT680.V4-07	Nut
8	MT680.V4-08	Sliding Plate
9	MT680.V4-09	Leading Plate
10	MT680.V4-10	Safety Plate Assembly
11	MT680.V4-11	Bolt
12	MT680.V4-12	Lock Washer
13	MT680.V4-13	Base Assembly
14	MT680.V4-14	Wheel, Fixed
15	MT680.V4-15	Lifting Arm, Outer
16	MT680.V4-16	Bolt
17	MT680.V4-17	Lifting Arm, Inner
18	MT680.V4-18	Bolt
19	MT680.V4-19	Lock Nut
20	MT680.V4-20	Air/Manual pump
21	MT680.V4-21	Washer
22	MT680.V4-22	Lock Washer

Item	Part No.	Description
23	MT680.V4-23	Nut
24	MT680.V4-24	Adjusting Screw
25	MT680.V4-25	Rotatable Foot
26	MT680.V4-26	Bolt
27	MT680.V4-27	Ram
28	MT680.V4-28	Hydraulic Hose
29	MT680.V4-29	Hose Coupler
30	MT680.V4-30	Bolt
31	MT680.V4-31	Lock Nut
32	MT680.V4-32	Washer
33	MT680.V4-33	Bolt
34	MT680.V4-34	Lock Nut
35	SN12.S	Steel Nut M12
36	MT680.V4-36	Safety Handle
37	MT680.V4-37	Safety Wire
38	FWM8.S	Flat Washer M8
39	MT680.V4-39	Bolt
40	MT680.V4-40	Crank Handle Assembly
41	MT680.V4-41	Side Extension
42	MT680.V4-42	Connecting Bar
43	MT680.V4-43	Extension, Ramp
44	MT680.V4-44	Position Pin

NOTE: It is our policy to continually improve products and as such we reserve the right to alter data, specifications and component parts without prior notice. There may be alternative versions of this product, please contact us should you require this information.

IMPORTANT: No liability is accepted for incorrect use of product. Spare parts must be fitted by a competent person

WARRANTY: Guarantee is 12 months from purchase date, proof of which will be required for any claim.

Sealey Group, Kempson Way, Suffolk Business Park, Bury St Edmunds, Suffolk. IP32 7AR



01284 757500



01284 703534



sales@sealey.co.uk



www.sealey.co.uk