



INSTRUCTIONS FOR

PREMIER ENGINE CRANE 1 TONNE & 2 TONNE - FOLDING

MODEL NO: **PFC101, PFC201**

Thank you for purchasing a Sealey product. Manufactured to a high standard, this product will, if used according to these instructions, and properly maintained, give you years of trouble free performance.

IMPORTANT: PLEASE READ THESE INSTRUCTIONS CAREFULLY. NOTE THE SAFE OPERATIONAL REQUIREMENTS, WARNINGS & CAUTIONS. USE THE PRODUCT CORRECTLY AND WITH CARE FOR THE PURPOSE FOR WHICH IT IS INTENDED. FAILURE TO DO SO MAY CAUSE DAMAGE AND/OR PERSONAL INJURY AND WILL INVALIDATE THE WARRANTY. KEEP THESE INSTRUCTIONS SAFE FOR FUTURE USE.



Refer to instructions



Wear protective gloves



Wear safety footwear



Wear protective clothing

1. SAFETY

- ✓ Keep crane, lifting slings, support and beams in good working order and condition. Take immediate action to repair or replace damaged parts by contacting your supplier. Ensure that all accessory lifting devices are suitably certified.
- ☐ **WARNING!** If crane is damaged, remove from service immediately.
- ✓ Ensure the surface on which the crane is used is level, firm and capable of supporting the weight of the crane with maximum load - we recommend concrete. Never use the crane on tarmac or other soft surfaces.
- ✓ Ensure the crane legs and arms are locked in position before use.
- ✓ Keep children and unauthorised persons away from the working area.
- ✓ Keep working area clean and tidy, free from unrelated materials and ensure that there is adequate lighting.
- ✓ Ensure that load does not exceed the maximum lifting capacity of the crane. Overloading the crane is dangerous. Where appropriate, use only the lifting points recommended by the manufacturer of the item to be lifted, e.g. vehicle engine.
- ✓ Before lifting the load ensure that the crane jib is in the lowest practical position, that there are no obstacles which may snag the load whilst it is being lifted and that the area above the jib is clear.
- ✓ To avoid injury, be fully aware of your own and other persons locations in relation to the lifting and lowering, of the load.
- ✓ Keep a sound footing and balance, and ensure the floor is not slippery.
- ✓ Ensure jib extension is locked in position before lifting.
- ✓ Ensure the centre of gravity always remains inside the crane base.
- * **DO NOT** harness the load at an angle or use any attachments not verified as fit for purpose.
- * **DO NOT** allow the load to swing during lifting.
- * **DO NOT** allow the load to drop suddenly. Lower load with care, ensuring that you are fully aware of the condition of the surface onto which the load is to be placed.
- * **DO NOT** load crane beyond its rated capacity for each specified jib extension position as indicated on the adhesive label. The capacity of the crane reduces as the jib is extended.
- * **DO NOT** position any part of your body beneath the load.
- * **DO NOT** use the crane to move or transport a load other than for repositioning. The crane is a lifting device only.
- * **DO NOT** apply any sideways pressure to any part of the crane during lifting or when a load is suspended.
- * **DO NOT** attempt to adjust the safety valve, which has been set and sealed by the manufacturer.
- * **DO NOT** use this product to perform a task for which it is not designed.
- * **DO NOT** use whilst under the influence of drugs, alcohol or intoxicating medication.
- * **DO NOT** climb on the crane.
- ✓ When not in use fold the crane down and store in a safe, dry, childproof area.
- ✓ This crane is designed for lifting within a garage or workshop environment.
- ☐ **WARNING!** Failure to heed safety and warning instructions may result in damage and/or personal injury and will invalidate the warranty.

2. INTRODUCTION

Professional 1tonne (2tonne) folding crane with parallel legs for various lifting situations and heavy-duty forged hook. Features dead man's control to prevent accidental lowering. Lowers rapidly with no load whilst providing a smooth, controlled lowering under load conditions. Beam can be set in four positions, with a capacity of 700kg (1250kg) at its full extension of 1300mm (1610mm). Swivel pump aids use where space is limited. fast folding for easy storage and transportation. Weights 81kg (145kg) and is suitable for workshop use or by the serious motoring enthusiast.

3. SPECIFICATION

Model No.....	PFC101.....	PFC201
Lifting Capacity Position 1.....	1000kg.....	2000kg
Lifting Capacity Position 2.....	900kg.....	1750kg
Lifting Capacity Position 3.....	800kg.....	1500kg
Lifting Capacity Position 4.....	700kg.....	1250kg
Max. Lift Ht. at Max. Jib Ext. Position 1.....	2040mm.....	2160mm
Max. Lift Ht. at Max. Jib Ext. Position 2.....	2100mm.....	2210mm
Max. Lift Ht. at Max. Jib Ext. Position 3.....	2160mm.....	2280mm
Max. Lift Ht. at Max. Jib Ext. Position 4.....	2210mm.....	2350mm
Length of Jib Position 1.....	960mm.....	1200mm
Length of Jib Position 2.....	1073mm.....	1336mm
Length of Jib Position 3.....	1187mm.....	1473mm
Length of Jib Position 4.....	1300mm.....	2350mm
Height Jib Down.....	1580mm.....	1740mm
Length.....	1480mm.....	1750mm
Rear Width.....	300mm.....	300mm
Width Inside Front Frame.....	860mm.....	1080mm
Width Front Frame.....	960mm.....	1180mm
Height Legs Folded.....	1580mm.....	1740mm
Height of Frame.....	112mm.....	150mm
Weight.....	81kg.....	145kg
Oil Capacity.....	530ml.....	1025ml

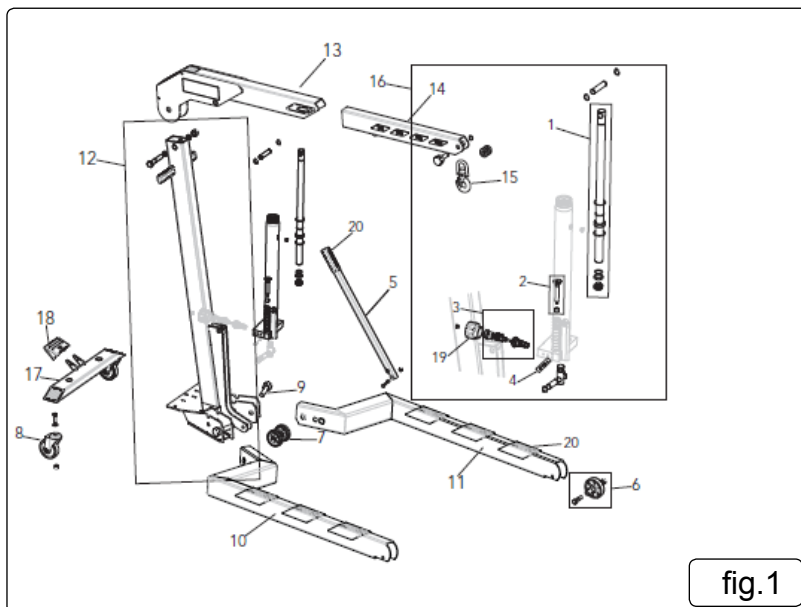

fig.1

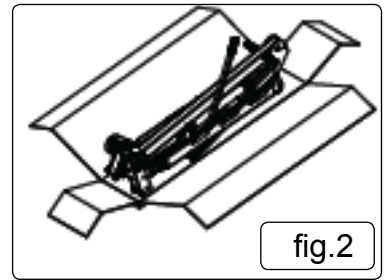

fig.2

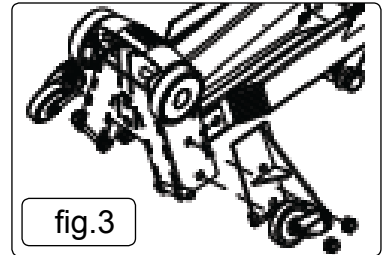

fig.3

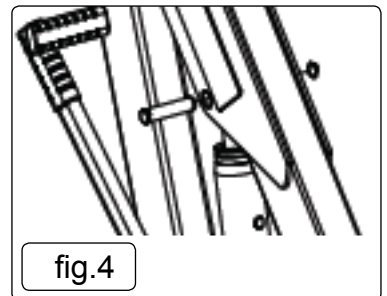

fig.4

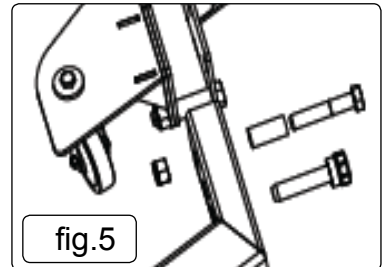

fig.5

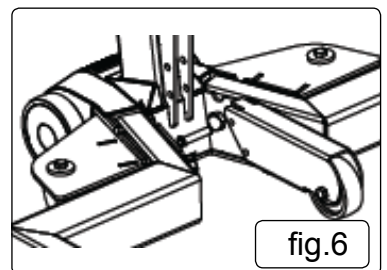

fig.6

4. OPERATION

- 4.1. It is essential to carry out the following assembly processes with the help of other people.
- 4.2. Open the box and assemble the wheel brackets on the column (fig.2 / fig.3)
- 4.3. Lift the crane and attach the hydraulic unit to the arm using the pin & circlips. (fig.4). To assemble the legs, place the crane on the ground and introduce the rivet (9) and the screw in the position indicated (fig.5).
- 4.4. Attach the auxiliary wheel bracket with the pin and circlip (fig.6).
- 4.5. Prior to using the crane, the hydraulic circuit needs to be bled in order to eliminate any air from the system. Turn the hydraulic release knob (19) 90° while pumping the lever (5) several times. Return the knob (19) to its original position, the crane is now ready for use. Turn the hydraulic unit to work in the most comfortable position.
- 4.6. To lift the load, pump lever (5). If lifting an engine, secure it at the points recommended by the manufacturer.
- 4.7. To lower the load, turn the knob (5). This system enables the lowering to be regulated and controlled manually and precisely. As another safety element, the crane is fitted with an LCS system to avoid jerky lowering, resulting from a possible incorrect manoeuvre. The crane will stop the lowering process when the knob is not activated.
- 4.8. When the crane is not in use the slide should be moved to its minimum length, and the piston of the hydraulic unit should be fully retracted.

5. MAINTENANCE

- 5.1. The maintenance and repair of this crane may only be carried out by qualified and authorized personnel, who as a result of their training and experience are familiar with the hydraulic systems used in these devices.
- 5.2. Clean and lubricate the axes of the moving parts of the crane at regular intervals. The crane should be kept clean and protected from aggressive conditions at all times.
- 5.3. Only original spare parts should be used.
- 5.4. Withdraw the crane from service if it is suspected that it has been subjected to abnormal loads or has suffered any type of knock until the unit has been inspected and any problem has been resolved.
- 5.5. If the oil level needs to be checked or refilled, dismantle the hydraulic unit and with piston fully retracted, remove the filler plug and drain its contents into a container. With the hydraulic unit in a horizontal position, proceed to introduce the necessary volume for each model as indicated. Avoid dirt entering the system with the new oil.
An excess of oil over the volume required may affect the operation of the crane.
- 5.6. Only use hydraulic oil, HL or HM type, with an ISO grade of cinematic viscosity of 30cST at 40°, or of an Engler viscosity of 3 at 50°C. Never use brake fluid.
- 5.7. When the crane is not in use, it should be fully retracted in the lowest position so as to minimize piston corrosion. It is recommended to apply an anti-corrosion product to the main piston and to the pump.
- 5.8. Store the crane in a dry and clean place, out of the reach of children.

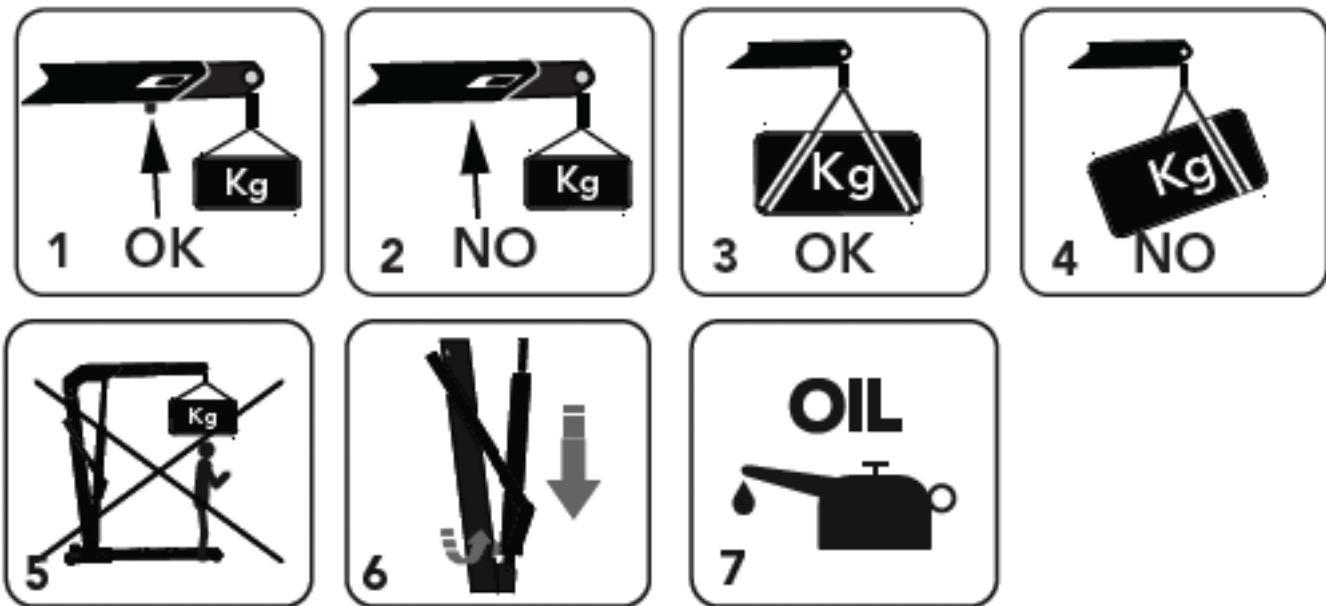

Parts support is available for this product. To obtain a parts listing and/or diagram, please log on to www.sealey.co.uk, email sales@sealey.co.uk or telephone 01284 757500.



Environmental Protection

Recycle unwanted materials instead of disposing of them as waste. All tools, accessories and packaging should be sorted, taken to a recycling centre and disposed of in a manner which is compatible with the environment. When the product becomes completely unserviceable and requires disposal, drain off any fluids (if applicable) into approved containers and dispose of the product and the fluids according to local regulations.

NOTE: It is our policy to continually improve products and as such we reserve the right to alter data, specifications and component parts without prior notice.

IMPORTANT: No liability is accepted for incorrect use of this product.

WARRANTY: Guarantee is 12 months from purchase date, proof of which will be required for any claim.



Sole UK Distributor, Sealey Group.
Kempson Way, Suffolk Business Park,
Bury St. Edmunds, Suffolk.
IP32 7AR



01284 757500



01284 703534



www.sealey.co.uk



sales@sealey.co.uk