



# PORTABLE PIVOT CAR LIFT 1500KG

MODEL NO: PPL01

Thank you for purchasing a Sealey product. Manufactured to a high standard, this product will, if used according to these instructions, and properly maintained, give you years of trouble free performance.

**IMPORTANT:** PLEASE READ THESE INSTRUCTIONS CAREFULLY. NOTE THE SAFE OPERATIONAL REQUIREMENTS, WARNINGS & CAUTIONS. USE THE PRODUCT CORRECTLY AND WITH CARE FOR THE PURPOSE FOR WHICH IT IS INTENDED. FAILURE TO DO SO MAY CAUSE DAMAGE AND/OR PERSONAL INJURY AND WILL INVALIDATE THE WARRANTY. KEEP THESE INSTRUCTIONS SAFE FOR FUTURE USE.



Refer to instruction manual



Wear safety footwear



Warning! Crushing of hands

## 1. SAFETY

- WARNING!** Ensure Health & Safety, local authority, and general workshop practice regulations are adhered to when using this equipment.
- WARNING! TRAPPING DANGER** – Although the vehicle lift movements are slow in operation, keep hands and limbs away from the steelwork during elevating and lowering.
- ✓ Keep the work area clean, uncluttered and ensure there is adequate lighting.
- ✓ Maintain correct balance and footing. Ensure the floor is not slippery and wear non-slip steel toe capped shoes.
- ✓ Remove ill-fitting clothes. Remove ties, watches, rings, other loose jewellery.
- ✓ Familiarise yourself with the applications, limitations and potential hazards of the vehicle lift.
- ✓ Once the load is lifted it is imperative that the load is locked by means of the anti-tilt arm.
- ✗ **DO NOT work under the vehicle without having first supported it with correctly rated axle stands.**
- ✓ The anti-tilt arm gives additional safety, but does **NOT** remove the need to use axle stands.
- ✓ Use on a hard, level non-slippery surface such as concrete that is capable of supporting the load of the vehicle and the lift.
- ✓ Check the load is stable on the lift, make sure there is no risk of tilting or slipping.
- ✗ **DO NOT** try to move the vehicle when it is on the lift.
- ✗ **DO NOT** modify the lift.
- ✗ **DO NOT** drive onto the lift.
- ✓ The lift is designed for lifting cars. Any other use is strictly forbidden.
- ✓ When lifting or lowering a car **DO NOT** allow anyone other than the operator to approach the work area.
- ✗ **DO NOT** use to achieve a task the vehicle lift was not designed to perform.
- ✓ Follow the drill's instructions, because of the risks presented by an electrical supply **DO NOT** use near water.
- ✗ **DO NOT** when lifting or lowering keep the vehicle balanced on the lift. The vehicle must rest freely on the front or rear wheels. Refer to section 4 for the procedure.
- ✗ **DO NOT** allow untrained persons to assemble or use the vehicle lift.
- ✗ **DO NOT** lift the vehicle with people inside.
- ✗ **DO NOT** exceed the load capacity of 1.5tonne. Refer to vehicle manufacturer's manual for weight of vehicle.
- ✓ Ensure adequate level space around the vehicle for the operator and the lift.
- ✗ **DO NOT** operate the vehicle lift if parts are damaged or missing as this may cause failure and/or personal injury.
- ✓ Before using lift, make a visual inspection of the vehicle lift to ensure there is no sign of damage or loose fixings.
- ✓ Before commencing lift ensure the vehicle bodywork is structurally sound. Refer to manufacturer's manual for information as to whether it is possible to lift the vehicle using the sills. Modern vehicles make extensive use of sill covers and extensions. Ensure there is sound strong, steel to lift the weight on.
- ✓ Before commencing the vehicle lift the vehicle hand brake must be off and leave in neutral.
- WARNING! The warnings, cautions and instructions in this manual cannot cover all possible conditions and situations that may occur. It must be understood by the operator that common sense and caution are factors which cannot be built into this product, but must be applied by the operator.**

## 2. INTRODUCTION





Compact and easy to raise a vehicle either manually or with an electric drill of 90Nm or more (do not use an impact wrench as this will damage the mechanism). During raising it can be stopped and at any height tilted.

## 3. SPECIFICATION

Model no.....PPL01  
Capacity .....1500kg  
Angled locking positions.....5  
Max. lift height .....585mm  
Overall size (W x D x H)..... 1185 x 775 x 160mm

# 4. CONTENTS

## Fittings

<b>B</b>		4
<b>C</b>		1
<b>D</b>	 6x25mm	2
<b>E</b>	 8x16mm	2
<b>F</b>		1

<b>G</b>	 8x35mm	4
<b>H</b>	 8x55mm	4
<b>I</b>	 M5x25mm	2
<b>J</b>	 M5x20mm	2
<b>K</b>		1
<b>L</b>		1

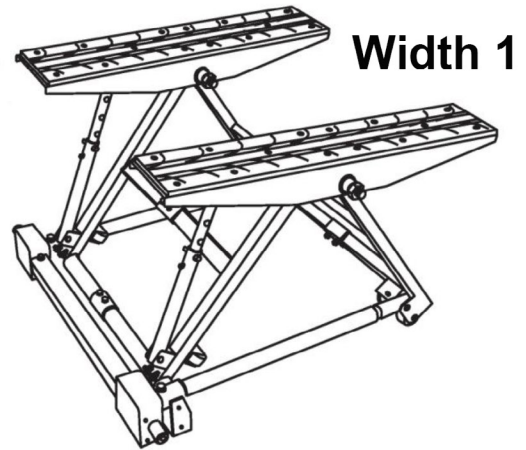

## Extension Pieces Width 2

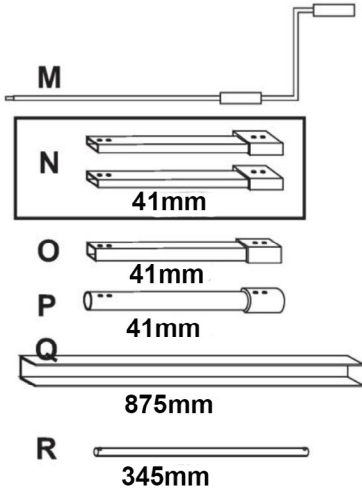

## Extension Pieces Width 3

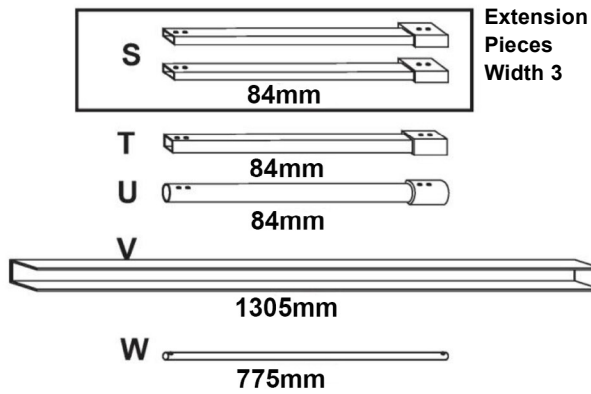

## Width 1

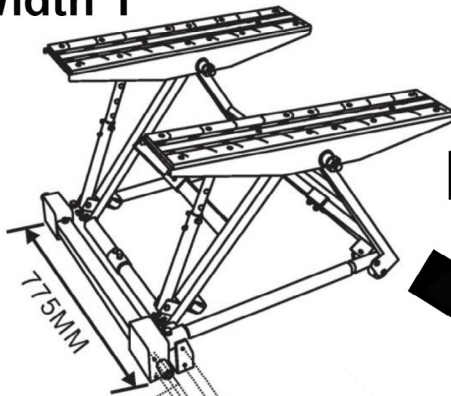

## Width 2

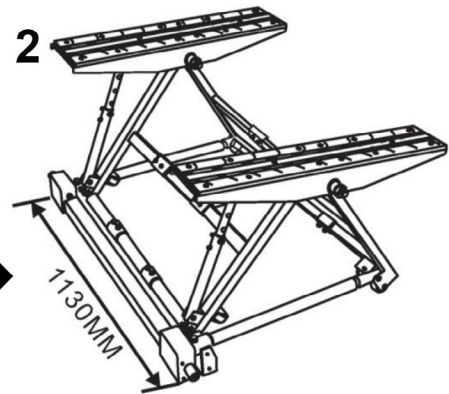

## Width 3

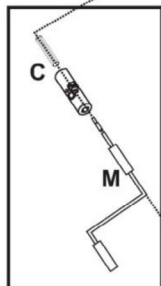
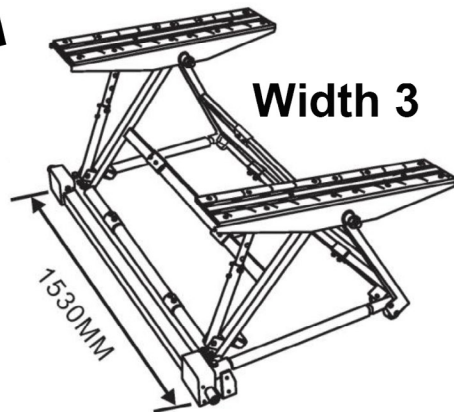

Manual operation

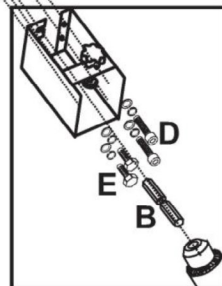

Electric operation

## Width 2

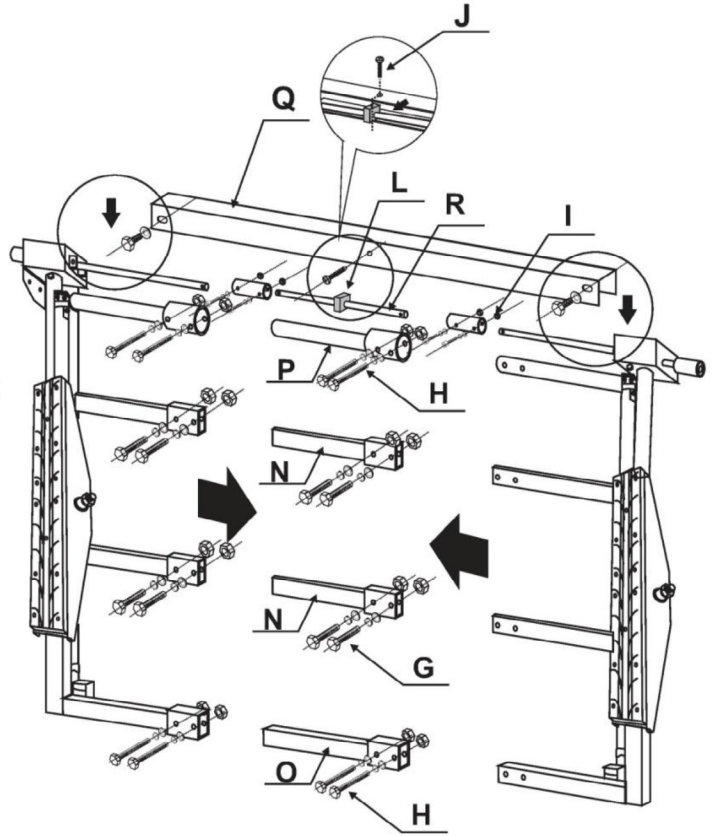
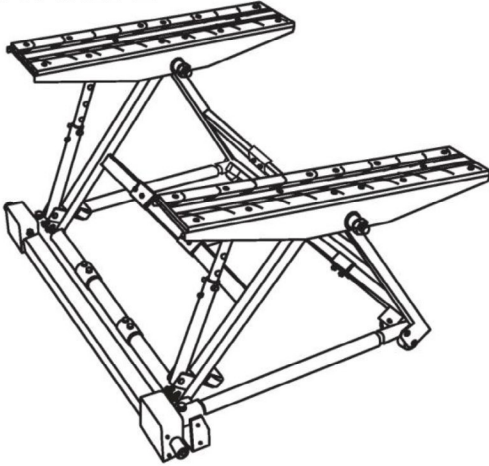

## Width 3

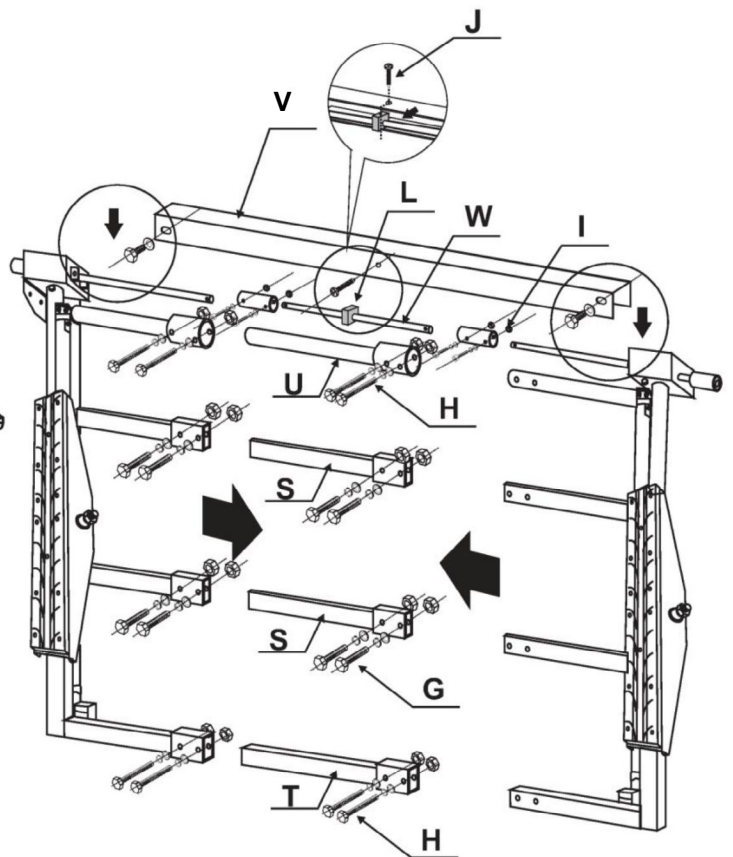
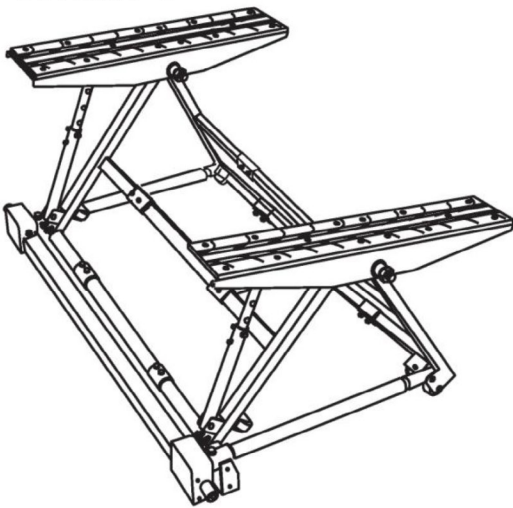

## 5. ASSEMBLY

### 5.1. MANUAL OPERATION (Refer to Fittings List section 4)

5.1.1. Use Contents C and handle M to raise and lower.

### 5.2. ELECTRIC OPERATION

☐ **WARNING! DO NOT** use air tools.

5.2.1. Fit F electric drill drive housing. Refer to fig.A for fixings.

### 5.3. WIDTH ADJUSTMENT

**To adjust the width of the lift refer to the Width 1, 2 & 3 diagrams in Section 4 Contents**

5.3.1. Remove the side cover, C section cover (this protects the drive shaft).

5.3.2. Undo the screws on K (this holds the two halves of the drive shaft together).

5.3.3. Undo the four sets of nuts and screws that hold the two halves of the car lift together.

5.3.4. Refer to the vehicle to be lifted and select the correct extension pieces (either Width 2 or 3).

**NOTE:** It may be necessary to use a rubber mallet to separate the two halves of the lift.

5.3.5. Fit the extension pieces, using the extra sets of screws supplied.

5.3.6. Fit the drive shaft extension piece and remember to fit the rubber block part L and secure through part Q or V using self tapping screws J.

5.3.7. Check that all fixings are secure.

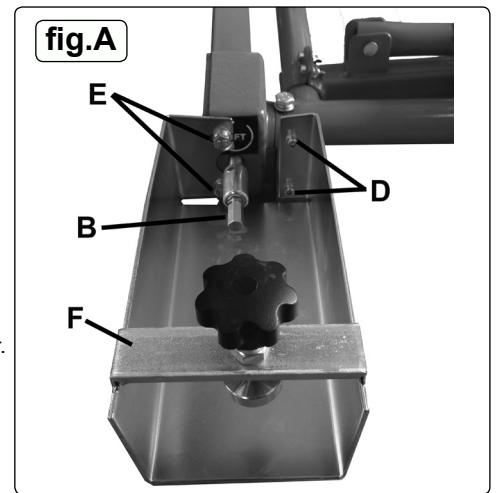

## 6. OPERATION

### 6.1. GENERAL CONSIDERATIONS

6.1.1. Use on a flat, hard, smooth floor (for example, concrete). A rough floor can hinder the working of the Mini Lift, by putting up too much resistance to the movement of the castors.

6.1.2. Before lifting or lowering the load, systematically check that the obstacles preventing the descent (jack stands and anti-tilt arm) are removed.

### 6.1.3. Load Limitation

6.1.3.1. The connecting pin B (Section 4 Contents) between the drill and the Mini Lift acts as a protection in the event of excessive load or when the maximum height is reached.

6.1.3.2. In these situations, the breaking of this pin is normal. Replace this pin with a genuine new pin, then continue using, making sure that the instructions for maximum load and height are followed.

\* **DO NOT** use the Mini lift with a pin different to the one originally supplied.

6.1.4. The load limiting pin is going to break if the user overrides the stops by continuing to operate the drill.

6.1.4.1. The Mini Lift is fitted with end stops, for the maximum lift position and the lowest position. Before reaching the end of the lift, it is therefore necessary TO GRADUALLY SLOW the movement and to stop it before reaching the stop.

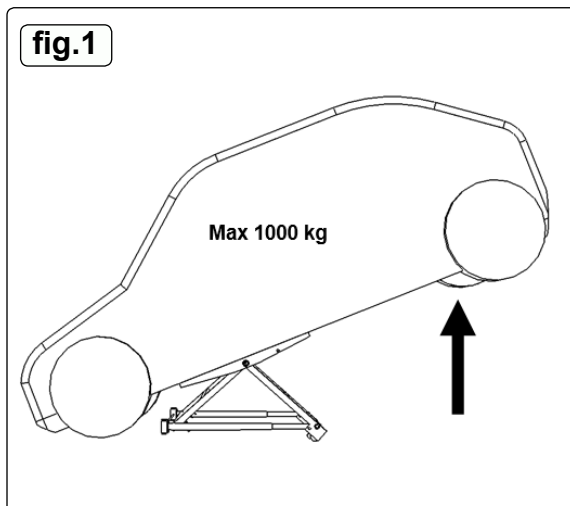

### 6.1.5. Lifting refer to fig's 1 & 2

6.1.5.1. When lifting the vehicle, **DO NOT** try to raise the 4 wheels simultaneously, but let it rest freely on the front or rear wheels.

6.1.5.2. The maximum lifting capacity is 1000 kg, which means you can lift heavier vehicles when 2 wheels are resting on the ground.

6.1.5.3. Once the vehicle is lifted, the maximum static capacity is 1500 kg. This means the vehicle can be placed horizontally with the four wheels lifted (if it does not exceed 1500 kg).

### 6.1.6. Moving refer to fig.3

☐ **WARNING!** The Mini Lift is heavy. **DO NOT** try to lift it yourself.

6.1.6.1. Take hold of the Mini Lift between the two drive housings and move it by rolling it on the castors located on the other side.

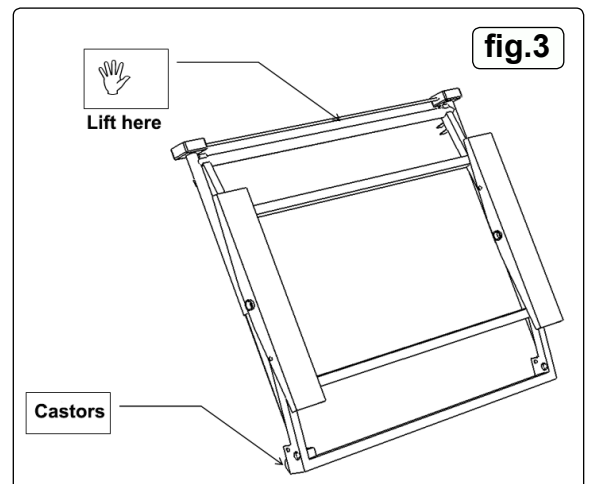
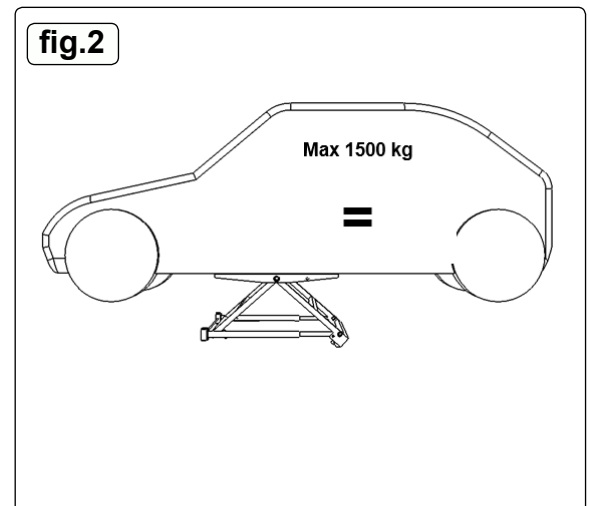

## 6.2. OPERATION

- 6.2.1. The vehicle must have the hand brake off and be in neutral. It must be on a horizontal surface so that it does not roll because of its own weight.
- 6.2.2. Place the Mini Lift at the side of the vehicle. The drive housings must be placed towards the front of the vehicle.
- 6.2.3. Slide the Mini Lift under the vehicle, until it is centred with the longitudinal axis of the vehicle. Adjust the distance between the runners to fit the width of the vehicle.
- 6.2.4. The two rubberised runners must be symmetrical in relation to the bottom of the car body. Check the manufacturer's manual to ensure that the runners are not in contact with any fragile component of the vehicle.

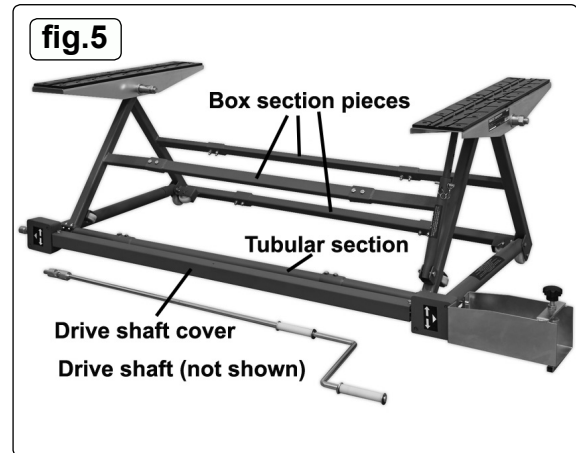

- 6.2.5. **To lift the front of the vehicle refer to fig.6**
- 6.2.5.1. Place the drive housings in contact with the front wheels of the vehicle (for front-engine vehicles).
- 6.2.6. **To lift the rear of the vehicle refer to fig.7**
- 6.2.6.1. Move the Mini Lift back slightly so that most of the weight is transferred onto the front.

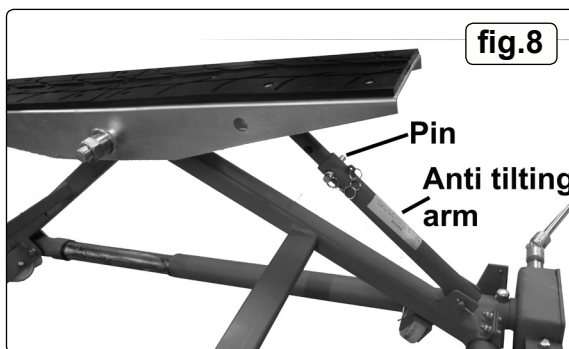
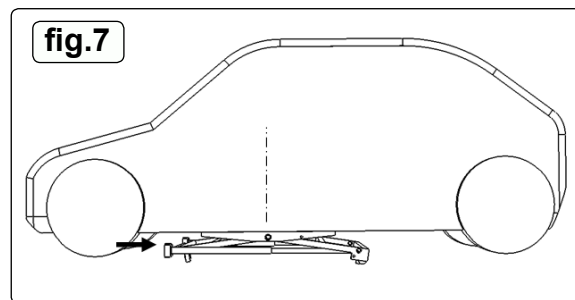
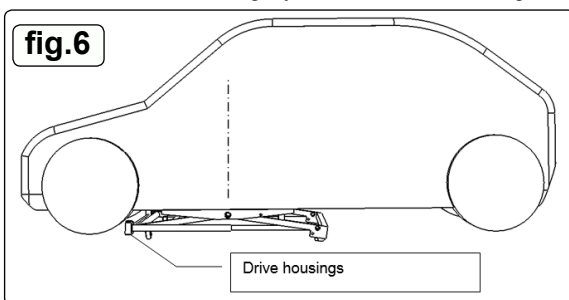

- 6.2.7. **Lifting (Electric Operation)**
- 6.2.7.1. Insert the connecting pin ( Section 4 Contents B) in the drill chuck. The cardan supplied is only for lifting with the crank.
- 6.2.7.2. Place the drill in the housing, inserting the connecting pin in the control shaft in the housing. Tighten the drill with the knob on the housing.
- 6.2.7.3. Operate the drill (direction of rotation to the right) holding it firmly.
- 6.2.7.4. Before reaching the maximum height, slow the lifting speed.
- 6.2.7.5. Insert the pin in the anti-tilting arm, refer to fig.8 .
- WARNING!** Check that the vehicle is stable before working underneath it. It must not be able to slip or tilt, even if the user should push against it while working. If there is a risk of the vehicle tilting, re-lower the Mini Lift and move it so as to place more weight on the wheels which remain on the ground.
  - WARNING! Install a pair axle stands before working under the vehicle.**  
Note: It is also possible to lift or lower the load using the crank and the cardan supplied.
- 6.2.8. **Lowering**
- 6.2.8.1. Remove the axle stands.
- 6.2.8.2. Remove the pin from the anti-tilt arm locking mechanism. If you forget to loosen this mechanism, it can lead to damage to the Mini Lift.
- 6.2.8.3. Operate the Mini Lift using the drill (or the crank), changing the direction of rotation.
- 6.2.8.4. Lower the Mini Lift until the load is no longer resting on it and it can easily be removed from the side.
- 6.2.8.5. Before reaching the minimum height, gradually slow the lowering speed.
- 6.2.9. **Tilting**
- WARNING!** Only for working on the front or the rear of the vehicle.

- 6.2.9.1. If the vehicle's centre of gravity is aligned with the axis of the Mini Lift, it can tend to tilt either forward or back. To avoid this, it is imperative to use axle stands and the anti-tilting arm.
- 6.2.9.2. In addition, it is **ESSENTIAL** that the axis of the Mini Lift is moved from the vehicle's axis of gravity, in order to place more load on the wheels that remain on the ground.
- 6.2.9.3. If one end of the vehicle is raised and the user wishes to work on the other end, you must lower it and then lift it again having changed the position of the Mini Lift to change the distribution of the load and lift the desired end.
- 6.2.10. Safety Nut**
- 6.2.10.1. The drive nut for the load can wear over time or if it is badly lubricated. In this case, a safety device holds the load, but it is no longer possible to lift or lower it.
  - × **DO NOT** try to repair the Mini Lift so that you can continue to use it: only Sealey must be entrusted with the repair.

## 7. STORAGE

- 7.1. The Mini Lift must be stored on the housings or fixed to the wall with brackets (not supplied.) Store in a dry, condensation free place.

## 8. MAINTENANCE

- 8.1. Grease the drives in the drive housings and the moving parts at least four times a year, or more often in the case of intensive use.
- 8.2. To grease the drives, take out the 2 screws and open the covers of the housings.



### ENVIRONMENT PROTECTION

Recycle unwanted materials instead of disposing of them as waste. All tools, accessories and packaging should be sorted, taken to a recycling centre and disposed of in a manner which is compatible with the environment. When the product becomes completely unserviceable and requires disposal, drain any fluids (if applicable) into approved containers and dispose of the product and fluids according to local regulations.

**Note:** It is our policy to continually improve products and as such we reserve the right to alter data, specifications and component parts without prior notice.

**Important:** No Liability is accepted for incorrect use of this product.

**Warranty:** Guarantee is 12 months from purchase date, proof of which is required for any claim.

Sealey Group, Kempson Way, Suffolk Business Park, Bury St Edmunds, Suffolk. IP32 7AR



01284 757500



01284 703534



sales@sealey.co.uk



www.sealey.co.uk