

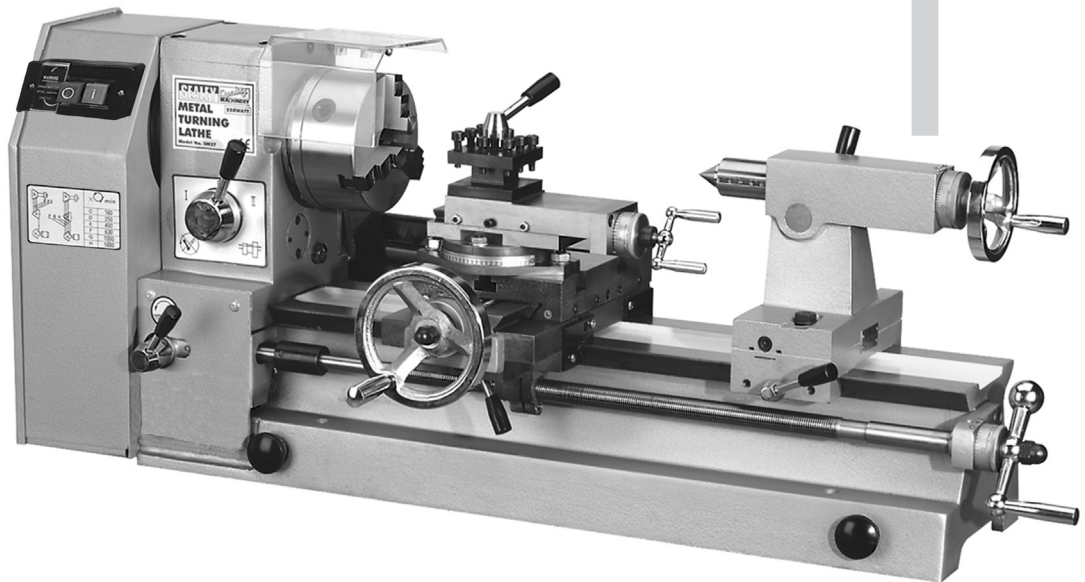

INSTRUCTIONS FOR: METAL TURNING LATHE



MODEL: SM27.V2



INSTRUCTIONS FOR: METAL TURNING LATHE

MODEL No: **SM27.V2**

Thank you for purchasing a Sealey product. Manufactured to a high standard, this product will, if used according to these instructions, and properly maintained, give you years of trouble free performance.

IMPORTANT: PLEASE READ THESE INSTRUCTIONS CAREFULLY. NOTE THE SAFE OPERATIONAL REQUIREMENTS, WARNINGS & CAUTIONS. USE THE PRODUCT CORRECTLY AND WITH CARE FOR THE PURPOSE FOR WHICH IT IS INTENDED. FAILURE TO DO SO MAY CAUSE DAMAGE AND/OR PERSONAL INJURY AND WILL INVALIDATE THE WARRANTY. KEEP THESE INSTRUCTIONS SAFE FOR FUTURE USE.



Refer to
instruction
manual



Wear eye
protection

1. SAFETY

1.1. Electrical Safety

WARNING! It is the responsibility of the owner and the operator to read, understand and comply with the following:

You must check all electrical products, before use, to ensure that they are safe. You must inspect power cables, plugs, sockets and any other connectors for wear or damage. You must ensure that the risk of electric shock is minimised by the installation of appropriate safety devices. A Residual Current Circuit Breaker (RCCB) should be incorporated in the main distribution board. We also recommend that a Residual Current Device (RCD) is used. It is particularly important to use an RCD with portable products that are plugged into a supply which is not protected by an RCCB. If in any doubt consult a qualified electrician. You may obtain a Residual Current Device by contacting your Sealey dealer.

You must also read and understand the following instructions concerning electrical safety:

1.1.1. **The Electricity at Work Act 1989** requires all portable electrical appliances, if used on business premises, to be tested by a qualified electrician, using a Portable Appliance Tester (PAT), at least once a year.

1.1.2. **The Health & Safety at Work Act 1974** makes owners of electrical appliances responsible for the safe condition of those appliances and the safety of the appliance operators. **If in any doubt about electrical safety, contact a qualified electrician.**

1.1.3. Ensure that the insulation on all cables and on the appliance is safe before connecting it to the power supply. See 1.1.1. and 1.1.2. and use a Portable Appliance Tester.

1.1.4. Ensure that cables are always protected against short circuit and overload.

1.1.5. Regularly inspect power supply cables and plugs for wear or damage and check all connections to ensure that none are loose.

1.1.6. **Important:** Ensure that the voltage marked on the appliance matches the power supply to be used and that the plug is fitted with the correct fuse - see fuse rating at right.

1.1.7. **DO NOT** pull or carry the appliance by the power cable.

1.1.8. **DO NOT** pull the plug from the socket by the cable.

1.1.9. **DO NOT** use worn or damaged cables, plugs or connectors. Immediately have any faulty item repaired or replaced by a qualified electrician. When a BS 1363/A UK 3 pin plug is damaged, cut the cable just above the plug and **dispose of the plug safely.**

Fit a new plug according to the following instructions (UK only).

a) Connect the GREEN/YELLOW earth wire to the earth terminal 'E'.

b) Connect the BROWN live wire to the live terminal 'L'.

c) Connect the BLUE neutral wire to the neutral terminal 'N'.

d) After wiring, check that there are no bare wires, that all wires have been correctly connected, that the cable outer insulation extends beyond the cable restraint and that the restraint is tight.

Double insulated products, which are always marked with this symbol , are fitted with live (brown) and neutral (blue) wires only. To rewire, connect the wires as indicated above - **DO NOT** connect either wire to the earth terminal.

1.1.10. Products which require more than 13Amps are supplied without a plug. In this case you must contact a qualified electrician to ensure that a suitably rated supply is available. We recommend that you discuss the installation of an industrial round pin plug and socket with your electrician.

1.1.11. If an extension reel is used it should be fully unwound before connection. A reel with an RCD fitted is preferred since any appliance plugged into it will be protected. The cable core section is important and should be at least 1.5mm², but to be absolutely sure that the capacity of the reel is suitable for this product and for others which may be used in the other output sockets, we recommend the use of 2.5mm² section cable.

1.2. General Safety

WARNING! Disconnect the lathe from the mains power and ensure that the chuck or face plate is at a complete standstill before attempting to change accessories, service or perform any maintenance.

✓ Maintain the lathe in good condition (use an authorised service agent).

✓ Replace or repair damaged parts. *Use recommended parts only. Unauthorised parts may be dangerous and will invalidate the warranty.*

✓ Locate the lathe in a suitable area. Ensure that the mounting surface is flat and firm. Keep the area clean and tidy and free from unrelated materials, and ensure that there is adequate lighting.

✓ Keep the lathe clean for best and safest performance.

WARNING! Before each use check that face plate/chuck, cutting tool and tailstock are secure and not worn or damaged. If any part of the lathe is worn or damaged replace immediately.

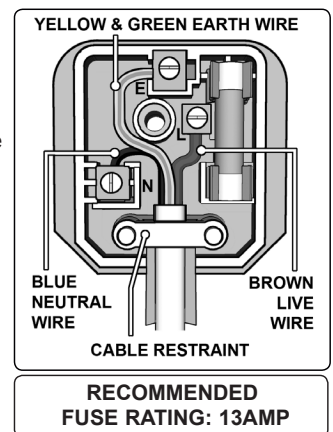

- ❑ **WARNING!** Keep chuck guard and holding fixings in place, tight and in good working order. The safety micro switch ensures that the lathe will not operate when the chuck guard is raised. Check regularly for damaged parts.
A chuck guard that is damaged or missing must be repaired or replaced before the lathe is next used.
- ❑ **WARNING! DO NOT** over-ride the chuck guard safety micro switch.
- ✓ Remove adjusting keys and wrenches from the lathe and its vicinity before turning it on.
- ❑ **WARNING!** Wear approved safety eye protection and, if oil mist is generated, respiratory protection.
- ✓ Remove ill fitting clothing. Remove ties, watches, rings and other loose jewellery and contain long hair.
- ✓ Keep hands and body clear of the workpiece when operating the lathe.
- ✓ Maintain correct balance and footing. Ensure that the floor is not slippery and wear non-slip shoes.
- ✓ Keep children and unauthorised persons away from the work area.
- ❑ **WARNING! DO NOT** switch on the lathe whilst the cutting tool is in contact with the workpiece. Bring the cutting tool gradually to the workpiece.
- ✓ Avoid un-intentional starting of the lathe.
- x **DO NOT** use the lathe for a task it is not designed to perform.
- x **DO NOT** allow untrained persons to operate the lathe.
- x **DO NOT** get the lathe wet or use in damp or wet locations or areas where there is condensation.
- ❑ **WARNING! DO NOT** use the lathe where there are flammable liquids, solids or gases such as petrol, paint solvents, waste wiping rags etc.
- x **DO NOT** operate the lathe if any parts are missing or damaged as this may cause failure and/or personal injury.
- x **DO NOT** lift or remove the chuck guard whilst the lathe is in use.
- x **DO NOT** touch the workpiece close to the cut as it will be very hot. Allow to cool.
- x **DO NOT** leave the lathe running unattended.
- x **DO NOT** operate the lathe when you are tired or under the influence of alcohol, drugs or intoxicating medication.
- ✓ When not in use switch off the lathe and isolate from the power supply.

2. INTRODUCTION

Quality workshop lathe suitable for a wide range of turning and drilling applications. Features power feed for even surface finish and thread cutting. Four-way tool post mounted on compound slide mechanism enables fast interchange of cutting tools with accurate feed. Powered by 550Watt motor through a six-speed gearbox. Incorporates quiet-running PTO gearbox with oil bath lubrication for power feed. Supplied with three-jaw chuck and dead centre. Fitted with no-load voltage release switch. Meets Supply of Machinery (Safety) Regulations 1992 (and amendments). Workshop stand available as an optional extra, Model No. SM27ST.V2.

3. SPECIFICATION

Motor 550W - 230V 50Hz
 Spindle Speed Range 160-1600rpm
 Distance Between Centres..... 500mm
 Centre Height Over Table..... 150mm
 Centre Height Over Saddle..... 80mm
 Spindle Bore..... 26mm

Headstock Taper. MT4
 Tailstock Taper MT3
 Tailstock Travel. 40mm
 Screw Cutting:
 Metric Pitches 14 in range 0.5-3mm
 Imperial Pitches 20 in range 11-40tpi

4. CONTENTS

- Lathe
- Face Plate
- Three-jaw (Internal) Chuck and Chuck Key
- External Chuck Jaws
- Centres, MT3 & MT4
- Gear Set, Thread Cutting, 13pc (Metric)
- Drive Belts, 2 Short, 1 Long
- 4 Hex Keys, 4, 5, 6 & 8mm
- 2 Spanners, 8x10mm & 17x19mm
- ❑ **WARNING! Safe handling will require two people.**
Note that the lathe has four pull-out handles (fig.1.6) to aid lifting.

5. ASSEMBLY

- 5.1. Unpack the product and check that all components and tools are present and undamaged. If any problem is noted contact your supplier immediately.
- 5.2. The machine has been coated with grease to protect it in shipping. Remove the coating with commercial degreaser, kerosene or similar solvent before use. After degreasing coat the machined surfaces with machine oil.
- 5.3. Position the lathe on a sturdy workbench or on the optional stand (Model No. SM27ST.V2). The lathe should be bolted directly to the workbench or stand through the four holes provided in the bed.

6. OPERATION

It is assumed that the operator has experience of machining practice and these instructions are intended only to describe the features of the lathe. If you have no experience of machining it is recommended that you undertake training before using this machine.

- ❑ **WARNING! Before operating the lathe ensure that you are wearing approved safety goggles and gloves to protect you from swarf and metal particles. If using cutting oil or coolant a face mask may be necessary to avoid breathing any vapour generated. Ensure that all other safety instructions in Section 1 are followed carefully.**

6.1. Initial start-up

- 6.1.1. Check that the forward/reverse switch is in the forward position (fig.1.9) and that the leadscrew lever (fig.2.A) is on zero.

Note that the forward/reverse switch must only be changed when the lathe is switched off.

- 6.1.2. Set the automatic feed lever (fig.2.B) to disengaged - turn clockwise.
- 6.1.3. Confirm that the cross slide is well clear of the chuck and that all keys, spanners etc. are clear of the machine. Move the cross slide along the lathe bed by turning leadscrew handle (fig.1.5).
- 6.1.4. Connect the lathe to the mains supply.
- 6.1.5. Lower the chuck guard.

Note that the lathe will only operate with the chuck guard lowered.

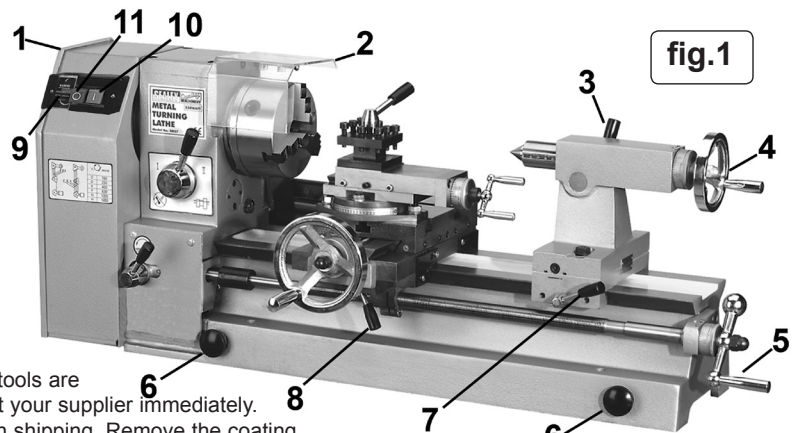

- 6.1.6. Switch on the lathe by pushing the green switch (fig.1.10).
- 6.1.7. For this initial start-up run the lathe for about five minutes.
- 6.1.8. Switch off the lathe by pressing the red switch (fig.1.11). Disconnect from the mains supply.
- 6.1.9. Check that nothing on the lathe has worked loose and that the mounting bolts are secure.

6.2. Headstock

The headstock spindle has an MT4 taper (internal) for the face plate or a spindle centre (see Accessories Section).

6.3. Tailstock

The tailstock spindle has an MT3 taper (internal) for a centre or chuck. See Accessories Section for the rolling centre and tailstock chuck. The spindle is positioned using the feed handle (fig.1.4) and then locked with the locking handle (fig.1.3).

The tailstock base may be moved along the lathe bed as necessary and locked in position by the locking lever (fig.1.7).

6.4. Tool Post

Up to four tools can be mounted on the tool post. The post can be rotated, in 90° steps, by slackening the locking handle (fig.3.1), and slightly lifting the post. **Always** ensure that the locking handle and tool clamp screws (fig.3.2) are tight before starting to cut. The tool post is mounted on the compound slide, which in turn is mounted on the cross slide. The compound slide can be rotated $\pm 60^\circ$ on the cross slide to permit **bevel and taper cutting**. To rotate the compound slide, loosen the two clamp nuts (fig.3.4) and rotate the slide to the required angle. Tighten the clamp nuts.

The cross slide can be locked in position along the bed by the locking lever (fig.1.8).

6.5. Chuck

The chuck is supplied with internal jaws fitted and a set of external jaws. To remove and fit jaws proceed as follows:

Using the chuck key, fully wind out the fitted jaws, at which point they can be pulled from the chuck.

The thread segments on the jaws are staggered and therefore the jaws are numbered 1 to 3 (on the inner end of the left location groove) and must be fitted in this sequence, in an anticlockwise direction (facing the chuck).

Turn the chuck key anticlockwise while watching the chuck thread in one of the jaw slots. When the end of the thread has just cleared the slot, stop turning the key and insert jaw 1 into this slot. Insert the other two jaws in the other slots in sequence.

Hold them under light pressure whilst turning the key clockwise until they are picked up by the thread and start to move inwards.

Check that the three jaws come together correctly at the centre of the chuck. If not, repeat the procedure.

6.6. Speed

The headstock spindle is belt driven and the speed is determined by the belt arrangement. To change the speed proceed as follows:

- 6.6.1. Open the belt cover (fig.1.1).
- 6.6.2. Slacken the motor adjuster nuts and the centre pulley nut (fig.4.A & B).
- 6.6.3. Position the belt(s) to give the required lathe speed, see fig.5.
- 6.6.4. Check that the weight of the motor is tensioning the belt(s) and then tighten the motor adjuster nuts and the centre pulley nut.

WARNING! Before starting the lathe always confirm that nothing will contact the chuck by rotating the chuck by hand with the tool post as far to the left as it will be during the turning operation. Make sure that the chuck guard is in place, as shown in fig.1.2. The lathe will not operate with the chuck guard raised.

6.7. Turning

6.7.1. Mount the cutting tool in the tool post such that the tip of the tool is level with, or just below, the lathe centre line. Check this by aligning the tool tip with the point of the tailstock. **The tool tip must not be above the centre line.** The height of the tool tip may be adjusted by shimming or grinding the tool.

6.7.2. Mount the workpiece in the chuck or on the face plate (optional, see Accessories Section) and, if necessary, support the other end with the tailstock. A fixed steady and a moving steady are also available, see Accessories Section.

6.7.3. Set the speed and forward/reverse switch to suit the job. The leadscrew lever (fig.2.A) should be at position O.

6.8. Turning with auto feed

6.8.1. Proceed as in 4.7. but in 4.7.3. set the leadscrew lever (fig. 2.A) to I or II. With the gear set as supplied, position I will feed the tool at 0.075mm/rev and position II at 0.15mm/rev (see Auto Feed for Turning, fig.7). Ensure that the cross slide lock (fig.1.8) is not applied.

6.8.2. Position the tool just to the right of the end of the workpiece and start the lathe.

6.8.3. Turn the auto feed lever (fig.2.B) anticlockwise to engage the leadscrew. The tool will now move to the left and begin cutting.

6.8.4. Be ready to disengage the leadscrew when the tool reaches the end of the cut. **DO NOT** allow the tool to over-travel and come into contact with the chuck.

Always be prepared to hit the stop button if the leadscrew cannot be disengaged.

6.9. Screw cutting

Similar to turning with auto feed except that the feed rate is very much faster, demanding increased care from the operator.

- 6.9.1. Select the required leadscrew gear train from the charts (fig.7).
- 6.9.2. Open the headstock end cover (fig.1.1).
- 6.9.3. Remove the gear retaining circlips and nut (fig.6.1, 2 & 3) and slacken the adjuster screw (fig.6.4).
- 6.9.4. Replace the existing gears with those required, in the positions shown in fig.8.
- 6.9.5. Adjust gears B and C, so that the train meshes with minimum backlash but without being tight.
- 6.9.6. Tighten adjuster screw (fig.6.4) and refit the end cover. **DO NOT operate the lathe with the end cover open.**

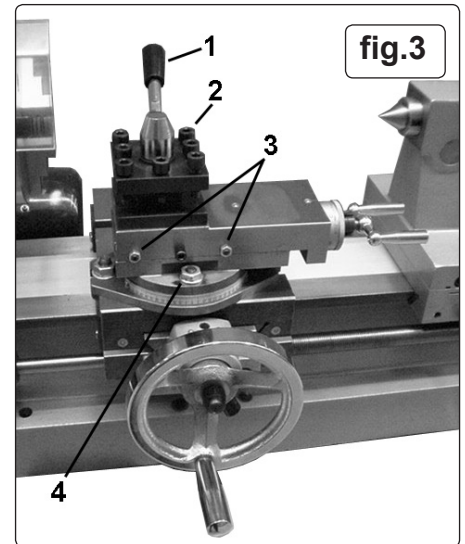
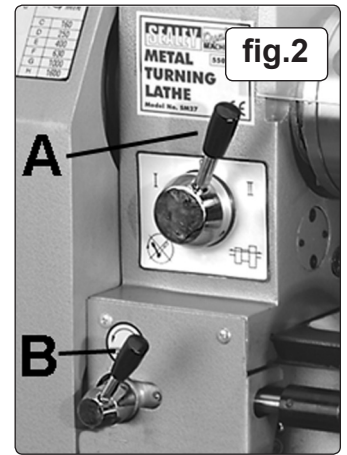

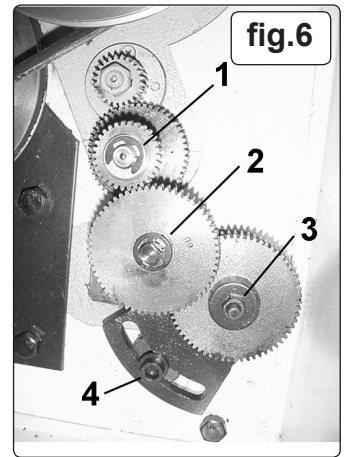
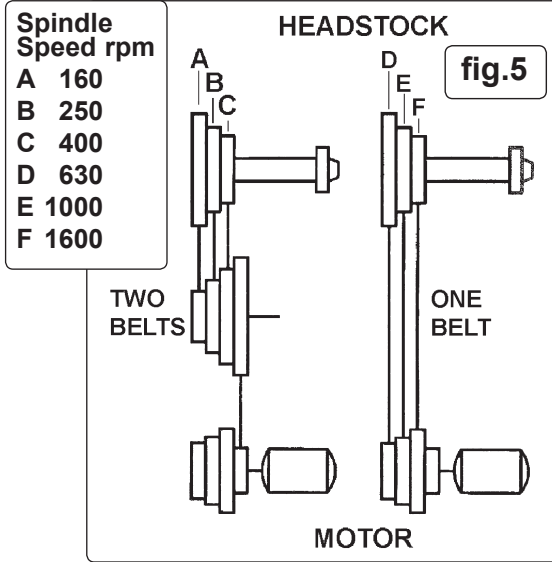
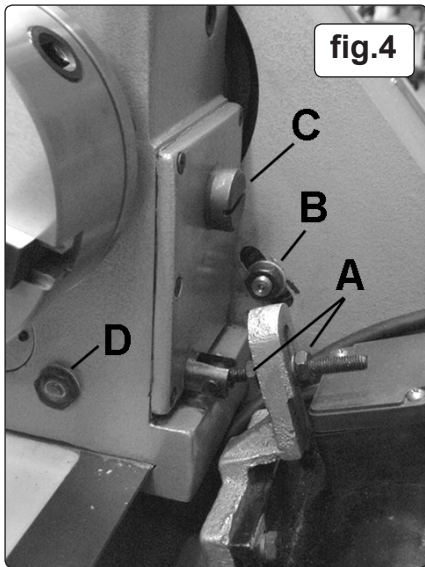

- 6.9.7. Mount the workpiece in the lathe with the left hand end of the intended thread as far from the chuck as possible.
- 6.9.8. With the tool positioned for the first cut, ensure that the automatic feed is engaged (fig.2.B) and that the leadscrew lever (fig.2.A) is set to I or II as required for the thread.
- 6.9.9. Ensure that the cross slide lock (fig.1.8) is not applied.
- 6.9.10. Lower the chuck guard and switch on the lathe.
- 6.9.11. When the tool reaches the end of the thread switch off the lathe. **DO NOT** disengage the leadscrew.
- 6.9.12. Reposition the tool for the second cut by moving the forward/reverse switch (fig.2.C) to reverse and starting the lathe. When the tool clears the start of the thread switch off the lathe.
- 6.9.13. Adjust the tool for the second cut and move the forward/reverse switch to forward.
- 6.9.14. Start the lathe for the second cut. Repeat as necessary to complete the thread cutting.

Auto Feed for Turning					
Feed Rate mm/rev	Gear Size (Teeth)				Leadscrew Lever
	A	B	C	D	
0.075	30	60	27	63	I
0.15	30	60	27	63	II

Metric Threads					
Thread Pitch mm	Gear Size (Teeth)				Leadscrew Lever
	A	B	C	D	
0.5	50	40	49	42	I
0.6	60	40	42	36	I
0.7	56	42	49	32	I
0.75	60	36	42	32	I
0.8	56	32	48	36	I
1.0	60	36	56	32	I
1.0	50	40	49	42	II
1.25	63	32	50	27	I
1.5	63	32	60	27	I
1.5	60	36	42	32	II
1.75	60	36	49	32	II
2.0	60	36	56	32	II
2.5	63	32	50	27	II
3.0	63	32	60	27	II

Imperial					
Threads Per Inch	Gear Size (Teeth)				Leadscrew Lever
	A	B	C	D	
40	50	36	56	42	I
38	50	57	60	27	I
36	50	54	60	27	I
34	60	51	50	27	I
32	60	48	50	27	I
30	56	42	50	27	I
28	60	42	50	27	I
26	60	39	50	27	I
24	60	36	50	27	I
22	60	33	50	27	I
20	50	36	56	42	II
19	50	57	60	27	II
18	50	54	60	27	II
17	60	51	50	27	II
16	60	48	50	27	II
15	56	42	50	27	II
14	60	42	50	27	II
13	60	39	50	27	II
12	60	36	50	27	II
11	60	33	50	27	II

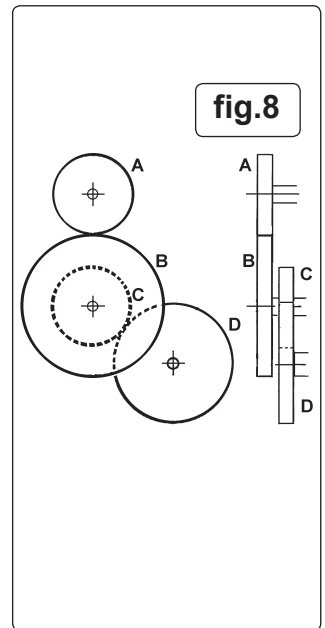

7. MAINTENANCE

☐ **WARNING!** Ensure that the lathe is unplugged from the power supply before attempting any maintenance.

7.1. Before each use:

- Lubricate the leadscrew bearings (oil point to left of scale at handle end and oil point behind gear D at driven end).
- Lubricate the leadscrew thread and the leadscrew gears.
- Lubricate the cross slide (oil point behind scale and two on front face of slide).
- Lubricate the compound slide (two oil points on top face).
- Lubricate the tailstock (two oil points on top face).

7.2. Cleaning

Clean the machine after each use and oil all machined surfaces.

7.3. Adjusting play in the slides

If any play becomes apparent in the slides adjust as follows:

- Loosen the lock nuts (compound slide only) of the gib strip adjusting screws (fig.3.3 shows the screws for the compound slide. Those for the cross slide are on the right-hand side of the slide, and those for the tail stock are either side of the locking lever).
- Lightly tighten the screws equally and check that the slide will not move with normal effort on the handle.
- Back-off each screw by $\frac{1}{4}$ of a turn (tighten the lock nuts, compound slide only).
- Check that there is no play and that the slide moves smoothly.
- If further adjustment is required, tighten or loosen the screws as necessary by $\frac{1}{8}$ of a turn only and recheck.

7.4. Headstock oil level

Headstock oil level should be at centre of sight glass (fig.4.D). If necessary top-up with a suitable oil via plug (fig.4.C)

Environmental Protection



Recycle unwanted materials instead of disposing of them as waste. All tools, accessories and packaging should be sorted, taken to a recycling centre and disposed of in a manner which is compatible with the environment.

When the product becomes completely unserviceable and requires disposal, drain off any fluids (if applicable) into approved containers and dispose of the product and the fluids according to local regulations.

WEEE Regulations



Dispose of this product at the end of its working life in compliance with the EU Directive on Waste Electrical and Electronic Equipment (WEEE). When the product is no longer required, it must be disposed of in an environmentally protective way. Contact your local solid waste authority for recycling information.

NOTE: It is our policy to continually improve products and as such we reserve the right to alter data, specifications and component parts without prior notice.

IMPORTANT: No liability is accepted for incorrect use of this product.

WARRANTY: Guarantee is 12 months from purchase date, proof of which will be required for any claim.



Sole UK Distributor, Sealey Group,
Kempson Way, Suffolk Business Park,
Bury St. Edmunds, Suffolk,
IP32 7AR

01284 757500

01284 703534

www.sealey.co.uk

sales@sealey.co.uk



ACCESSORIES FOR:
METAL TURNING LATHE
 MODEL No: **SM27.V2**

These accessories are available from your Sealey dealer.



Ø160mm

Face Plate - SM27FP



Ø160mm

4-Jaw Chuck & Back Plate - SM27FJC

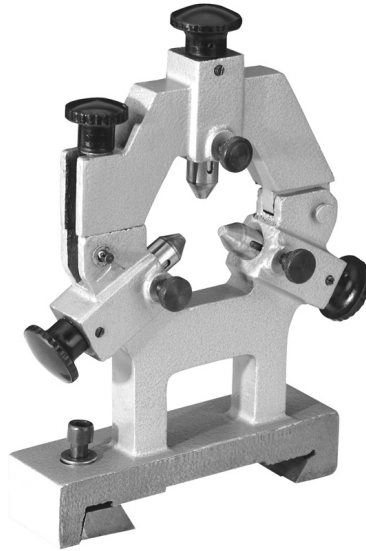

Fixed Steady - SM27FS

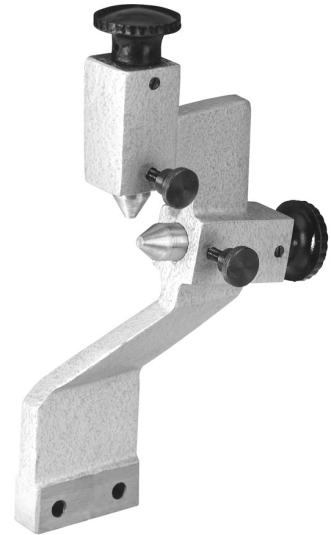

Moving Steady - SM27MS



Ø13mm, MT3

Tailstock Chuck & Arbor - SM27TC



MT3

Revolving Dead Centre - SM27RDC



T-Nut Set - SM27THNS

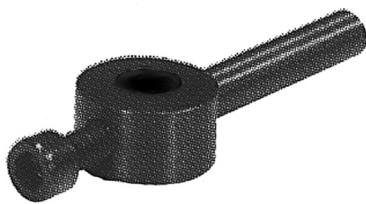

Lathe Dog - SM3002LD

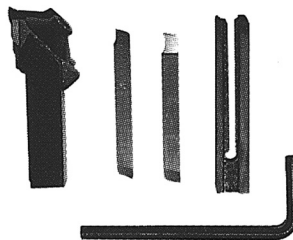

2pc Cutter Set - SM3002CS2

DIN4971R
 DIN4975
 DIN4980R
 DIN4980L
 DIN4981R

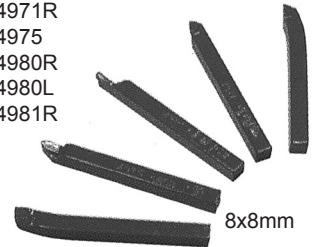

5pc Cutter Set - SM3002CS5

8x8mm

DIN4972R
 DIN4973R
 DIN4974R
 DIN4976R
 DIN4977R
 DIN4978R

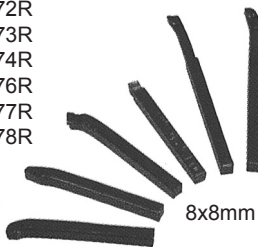

6pc Cutter Set - SM3002CS6

8x8mm

DIN4971R
 DIN4972R
 DIN4973R
 DIN4974R
 DIN4975
 DIN4976
 DIN4977R
 DIN4978R

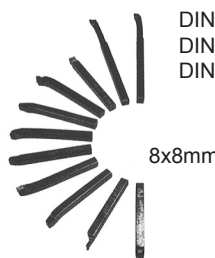

11pc Cutter Set - SM3002CS11

8x8mm

DIN4980L
 DIN4980R
 DIN4981R

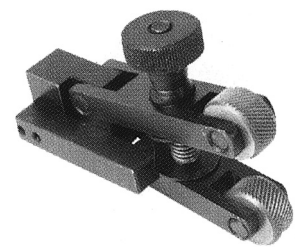

Knurling Tool Holder - SM3002KTH