



450MM 8 POWER TOOL RACK TROLLEY

MODEL NO: **APPTR8**

Thank you for purchasing a Sealey product. Manufactured to a high standard, this product will, if used according to these instructions, and properly maintained, give you years of trouble free performance.

IMPORTANT: PLEASE READ THESE INSTRUCTIONS CAREFULLY. NOTE THE SAFE OPERATIONAL REQUIREMENTS, WARNINGS & CAUTIONS. USE THE PRODUCT CORRECTLY AND WITH CARE FOR THE PURPOSE FOR WHICH IT IS INTENDED. FAILURE TO DO SO MAY CAUSE DAMAGE AND/OR PERSONAL INJURY AND WILL INVALIDATE THE WARRANTY. KEEP THESE INSTRUCTIONS SAFE FOR FUTURE USE.



Refer to instruction manual

fig.1

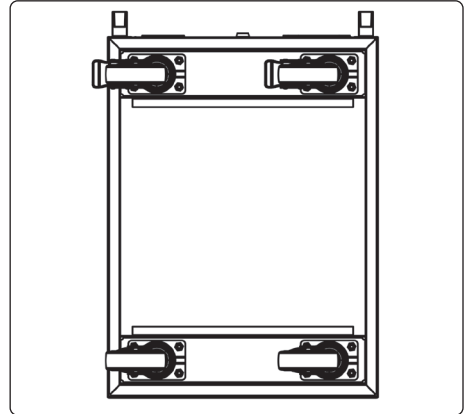

1. SAFETY

- ✓ To avoid tipping **DO NOT** open both drawers at the same time.
- ✗ **DO NOT** climb on the drawers or the trolley.
- ✓ Close and secure drawers when moving.

2. INTRODUCTION

450mm Workshop trolley capable of holding eight power tools. Heavy gauged steel construction with a rust and solvent resistant black crinkle effect finish. Two drawers, one lockable, add extra secure storage space. Drawers come with 45mm soft close ball-bearing slides and 2mm EVA liners. 18mm Pressed wood top. Two steering swivel castors with quick release toe locks and two fixed castors make it easy to manoeuvre around any workshop or garage.

3. SPECIFICATION

Model No: APPTR8
Overall Size (W x D x H):450 x 600 x 855mm

4. ASSEMBLY

4.1. FIT CASTERS

- 4.1.1. Lay trolley on its side, use original packaging or a piece of carpet to protect the trolley.
- 4.1.2. Fit castors with screws provided.

4.2. FIT HANDLES

- 4.2.1. Fit handles to front of trolley with screws provided.

4.3. REMOVE DRAWERS

To remove a drawer, pull the drawer out completely, press down the right tab and lift up the left tab, pull drawer off the slides.

To reinstall the drawer, realign with the internal drawer slide and push until it locks in place.

fig.2

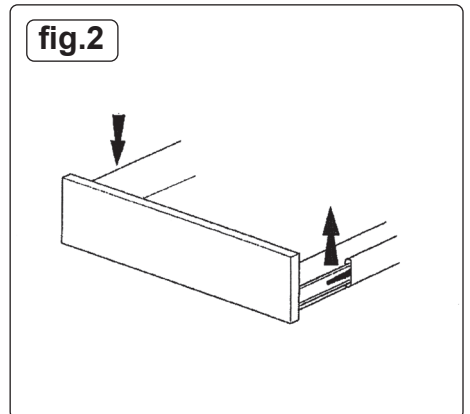

5. MAINTENANCE

Lubricate castors periodically, tighten all fixings.



ENVIRONMENT PROTECTION

Recycle unwanted materials instead of disposing of them as waste. All tools, accessories and packaging should be sorted, taken to a recycling centre and disposed of in a manner which is compatible with the environment. When the product becomes completely unserviceable and requires disposal, drain any fluids (if applicable) into approved containers and dispose of the product and fluids according to local regulations.

fig.3

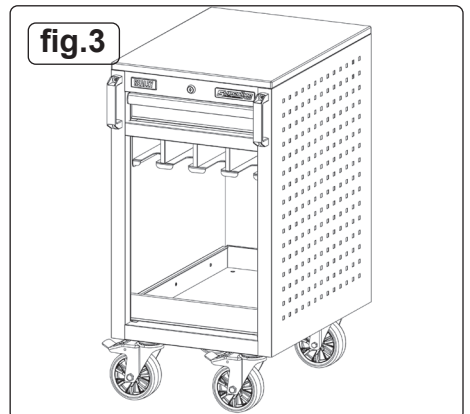

Note: It is our policy to continually improve products and as such we reserve the right to alter data, specifications and component parts without prior notice.

Important: No Liability is accepted for incorrect use of this product.

Warranty: Guarantee is 12 months from purchase date, proof of which is required for any claim.

Sealey Group, Kempson Way, Suffolk Business Park, Bury St Edmunds, Suffolk. IP32 7AR



01284 757500



01284 703534



sales@sealey.co.uk



www.sealey.co.uk